

DOCUMENT RESUME

ED 100 349

IR 001 447

AUTHOR Ballard, Richard; Eastwood, Lester F., Jr.  
TITLE Telecommunications Media for the Delivery of Educational Programming.  
INSTITUTION Washington Univ., St. Louis, Mo. Center for Development Technology.  
SPONS AGENCY National Science Foundation, Washington, D.C.  
REPORT NO WU-COT-M-74/1  
PUB DATE Nov 74  
NOTE 144p.

EDRS PRICE MF-\$0.75 HC-\$6.60 PLUS POSTAGE  
DESCRIPTORS Computer Assisted Instruction; Costs; \*Delivery Systems; \*Educational Programs; \*Educational Technology; Educational Television; Library Networks; Library Services; Library Technical Processes; Radio; \*Telecommunication; Telephone Communication Systems

IDENTIFIERS Picturephone; PLATO; TICCIT

ABSTRACT

A study was made of the technical characteristics and costs which might be incorporated into a network for the delivery of educational programming. Broadcast media explored include AM and FM radio and UHF and VHF television. Two systems of computer-assisted instruction, TICCIT and PLATO IV, were examined as was Bell Systems' Picturephone. Attention was devoted to application of interactive networks to library systems. The report contains 22 tables and seven figures and appendixes outlining the basic principles of PLATO IV which allows CAI to be transmitted by ordinary telephone lines.

(SK)

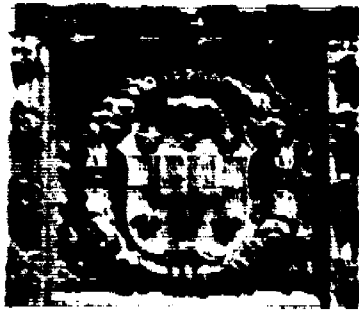

BEST COPY AVAILABLE

# WASHINGTON UNIVERSITY

---

CENTER FOR DEVELOPMENT TECHNOLOGY

MEMORANDUM No. 74/1

NOVEMBER, 1974

## TELECOMMUNICATIONS MEDIA FOR THE DELIVERY OF EDUCATIONAL PROGRAMMING

RICHARD BALLARD  
LESTER F. EASTWOOD, JR.

U.S. DEPARTMENT OF HEALTH, EDUCATION & WELFARE  
NATIONAL INSTITUTE OF EDUCATION  
EDUCATIONAL MEDIA CENTER  
1000 COLLEGE PARK DRIVE  
WASHINGTON, D.C. 20001

001447

ED100349

CENTER FOR DEVELOPMENT TECHNOLOGY  
Communications Group

WASHINGTON UNIVERSITY  
SAINT LOUIS, MISSOURI 63130

Memorandum No. 74/1

November, 1974

TELECOMMUNICATIONS MEDIA FOR THE DELIVERY OF  
EDUCATIONAL PROGRAMMING

RICHARD BALLARD  
LESTER F. EASTWOOD, JR.

BEST COPY AVAILABLE

This study was supported by the National Science Foundation under Grant No. EC-38871 and by the National Aeronautics and Space Administration under Grant No. NGR-26-008-054. The views expressed in this memorandum are those of the author and do not necessarily represent those of the Center for Development Technology, Washington University, or the sponsoring agency.

7

TABLE OF CONTENTS

No.		Page
1.	Introduction . . . . .	1
2.	Educational Radio . . . . .	5
2.1	Introduction . . . . .	5
2.2	Educational Radio Networks . . . . .	6
2.3	FM Educational Radio . . . . .	7
2.4	AM Educational Radio . . . . .	8
	2.4.1 Area of Coverage. . . . .	8
	2.4.2 Typical Costs for AM Radio. . . . .	15
2.5	Comparison: AM Broadcast Radio vs. FM Broadcast Radio. . . . .	19
3.	Broadcast Educational Television. . . . .	24
3.1	Introduction . . . . .	24
3.2	Regulations. . . . .	24
3.3	Costs. . . . .	29
3.4	Factors Inhibiting Broadcast Educational Television. . .	35
3.5	Educational Television Networks. . . . .	35
4.	Interactive Media for Education . . . . .	41
4.1	Interactive Television . . . . .	41
	4.1.1 TICCIT. . . . .	41
	4.1.2 Picturephone. . . . .	62
4.2	Computer-Aided Instruction (CAI) . . . . .	67
	4.2.1 The PLATO System. . . . .	67
	4.2.1.1 The Central Computer Facilities. . . . .	69
	4.2.1.2 The PLATO Student Terminal . . . . .	73
	4.2.1.3 Communications Network . . . . .	77
	4.2.1.4 Costs of the PLATO IV System . . . . .	81
5.	Library and Document Transmission Services. . . . .	85
5.1	Facsimile. . . . .	86

TABLE OF CONTENTS  
(continued)

No.	Page
5.1.1 Facsimile Transmitters . . . . .	86
5.1.2 Facsimile Recording Methods . . . . .	92
5.1.3 Signal Modulation Methods . . . . .	94
5.3 Applications of Facsimile and Television in Interactive Library Systems . . . . .	101
5.4 Interactive Indexing Considerations . . . . .	110
6. Summary and Conclusions . . . . .	115
6.1 Purpose of the Report; Relation to other Work . . . . .	115
6.2 Results of This Report . . . . .	117
APPENDICES	
A.1 Technical Properties of Information Transmission and Display . . . . .	121
A.2 Details of the Digitally Addressable Random Access Image Selector and Random Access Audio System Used in PLATO IV. . . . .	128
REFERENCES . . . . .	132

LIST OF TABLES

No.		Page
1.1	Restriction of FM Transmitter Power and Antenna Height by FCC Class of Station . . . . .	9
1.2	Prime Coverage Radii and Area for FM Broadcast Stations . . . . .	10
2.1	Cost of Typical Educational FM Programming Equipment (1970) . . . . .	11
2.2	Typical FM Transmitter Costs Versus Output Power Level (1970) . . . . .	12
2.3	Typical Personnel Requirements for an FM Educational Broadcasting Station . . . . .	13
3.1	AM Power Restrictions by FCC License Class . . . . .	16
3.2	Typical AM Coverage Radii and Areas by FDD License Class. . . . .	17
4.1	Cost of Typical Educational AM Programming Equipment (1970) . . . . .	18
4.2	Typical AM Transmitter Costs Versus Output Power Level (1970) . . . . .	20
4.3	Typical Personnel Requirements for an AM Educational Broadcasting Station . . . . .	21
5.1	Restriction of ERP and Antenna Height by Television Channel Assignment . . . . .	25
5.2	Minimum Field Intensity to be Provided Over Entire Principle Community Served in db. Above 1 $\mu$ v/meter (dbu). . . . .	27
6.	Maximum Limit of Coverage of Television Station by Channel Assignment and Antenna . . . . .	28
7.1	Broadcast Television Studio Equipment and Costs. . . . .	30
7.2	Operational Costs for Broadcast Television Studio. . . . .	31
8.	Typical UHF Station Costs Including Transmitter, Tower and Antenna. . . . .	32
9.1	Other UHF Broadcast Station Costs (Fixed Costs (1973)). . . . .	33
9.2	Broadcast Station Annual Operational Costs (Fixed Costs (1973)) . . . . .	34

LIST OF TABLES  
(continued).

No.		Page
10.	Costs of An Institutional TICCIT System. . . . .	44
11.	System Equipment Costs (1974). . . . .	60
12.	Picturephone <sup>®</sup> Hardward Costs. . . . .	66
13.	Typical Facsimile Transceiver Specifications and Prices. .	95

LIST OF FIGURES

No.		Page
1.	The Tree Configuration for Cable TV Networks . . . . .	46
2.	TICCIT Hub Configuration for Cable TV Network. . . . .	48
3.	Queueing Model for TICCIT Cell. . . . .	50
4.	Waiting Parameters for TICCIT System Versus Number of Terminals Per Cell . . . . .	55
5.	Waiting Parameters for TICCIT Systems Versus Per Terminal Load Factor . . . . .	56
6.	Waiting Parameters for TICCIT System versus Per Terminal Load Factor. . . . .	58
7.	Document Scanning Mechanism for the Flat Bed System of Facsimile . . . . .	89



# TELECOMMUNICATIONS MEDIA FOR THE DELIVERY OF EDUCATIONAL PROGRAMMING

## 1. INTRODUCTION

This paper examines the technical characteristics of various telecommunications media which might be incorporated into a network for the delivery of educational programming. Educational networks may be able to provide flexible, yet low-cost, delivery of educational services. Telecommunications networks for the delivery of education would allow sharing, to utilize more efficiently the limited resources that are available to the educational sector, while providing all segments of the educational community access to high-quality instructional services. Through its great flexibility and diversity, telecommunications technology can make education available to more people and more relevant to individual learner interests. A communications-based delivery system could serve learners whose schedules, locations or job responsibilities limit participation in the traditional education system.

The term, "educational network," as we use it, means an entity consisting of sets of connections between separate locations, a structure that dictates the direction of the flow of information within the network, and a set of terminals through which learners can ultimately receive information.

All facets of the network are highly dependent upon the type of instructional material to be carried by the network. An educational network might be as simple as an AM broadcast radio station transmitting musical selections and lectures having mass appeal to learners in a several-state area. On the other hand, an educational network might comprise a dedicated cable or microwave system, over which learners can request individualized computer-aided instruction or select and read any document in a million-volume library from interactive terminals located in their homes. The range of services which might be offered over educational networks is ultimately limited only by the amount of user support the services are able to generate.

As a prelude to the design and assessment of future educational networks, both established and presently developing electronic telecommunications media which can carry educational programming must be considered. Each of the different media has particular characteristics which determine its networking requirements and costs. Examples of these characteristics are bandwidth requirements, complexity of plant and terminal equipment, and programming development and selection. Thus, before designing a network to deliver a particular set of educational services, the services and the media which can carry them must be examined; they will determine the specifications which the network must satisfy. This paper will examine the various telecommunications media which might be used to deliver educational services, and will discuss their costs and network requirements in an attempt to act as a guide for the design of future educational networks.

Sections 2 and 3 of the paper consider the broadcast media: FM radio, AM radio, and VHF and UHF television. Although the broadcast

media are mostly limited to non-interactive programming, they allow educational programming to be delivered to large numbers of learners spread over areas now impractical to serve by other means. In addition, learners can receive the educational programming over existing receivers, making the per-user costs of receiving programming small in general. The costs and coverage abilities possible for educational broadcast stations are considered, along with the channel capacity and number of channels available. Examples of educational broadcasting networks, in which individual stations cooperate in producing and sharing educational programming, are also considered.

Section 4 of this paper deals with computer-aided instruction (CAI), an educational service which has the ability to deliver individualized instruction to learners by allowing them to interact with an educational computer system. The section discusses two existing systems capable of delivering interactive educational programming, TICCIT and PLATO IV, outlining their configurations, costs, and other design considerations. In addition, the Bell System's Picturephone<sup>(R)</sup>, a telecommunications medium which adds the video dimension to audio telephone service, is examined for possible use in delivering educational services.

Application of interactive networks to library systems is examined in Section 5. Microform technology, which could reduce large libraries into a physically much smaller, machine-accessible document collection, is discussed. The requirements of the network components with regard to the retrieval of individual documents, minimum acceptable image resolution and system bandwidth, along with techniques which might be used to transmit textual images to remote user terminals, are also considered. The New York Times Information Bank, a computerized

interactive index system having the ability to list relevant documents in its data base according to user-supplied subject descriptions, is examined for possible use in interactive library systems.

Finally, the paper has two appendices. The first briefly outlines some basic principles of communication theory for the purpose of giving the reader an understanding of the technical tradeoffs involved in the design of the educational media discussed in the main body of the paper. The second appendix describes the operation of PLATO IV's random access image selector and random access audio system, devices which allow versatile CAI to be transmitted over ordinary telephone lines.

## 2. EDUCATIONAL RADIO

Traditionally, educational services have been brought into the home through educational radio and television. These services provide cultural and educational programming over large areas, at no charge to those having appropriate receivers. This section delineates costs and technical considerations in educational radio.

### 2.1 INTRODUCTION

As of 1970, there were twenty-five AM (amplitude modulation) and 432 FM (frequency modulation) educational radio stations in the United States. (1) There are so few AM educational stations because, since 1940, the Federal Communications Commission (FCC) has discouraged the use of the AM broadcast band (535 kHz to 1605 kHz) for educational radio, preferring to assign frequencies in the portion of the FM broadcast band reserved for educational radio (88 MHz to 92 MHz), "unless it is shown there is a special need for the use of amplitude modulation." (1) However, AM educational radio is best used in covering large areas of low population density; AM radio can typically cover four times the area of an equally powered FM radio station. In such cases, its lower fidelity (5 kHz bandwidth for AM versus 15 kHz bandwidth for FM) and higher noise level would be acceptable because of the practical need to cover a given populated area economically.

This section will discuss the use of broadcast radio to disseminate educational services. Some of the educational radio networks which have been established to facilitate the exchange of high-quality educational programming between member stations are examined. The technical characteristics and costs for FM and AM educational radio are considered, and

the two services are compared in an attempt to outline their best use in delivering educational services.

## 2.2 EDUCATIONAL RADIO NETWORKS

Traditionally, educational radio has suffered from lack of funds, which prevented stations from generating large quantities of high quality programming. In response, many networks have been established for the purpose of distributing quality programming, either through the mails or through leased transmission lines. The National Educational Radio Network (NERN) is a national organization of educational radio stations which are served through the network headquarters in Urbana, Illinois. Through exchange of tape-recorded programs, it provides its affiliates with a minimum of 865 hours of new programming per quarter. The Eastern Educational Radio Network (EERN) is a group of Eastern radio stations which exchange recorded programs, cooperate in the production of shows, and occasionally interconnect studios to provide live remote programming. (1)

The Corporation for Public Broadcasting formed National Public Radio (NPR) in 1970 to provide national network programming for non-commercial public radio stations. Affiliation requires meeting transmitter power and scheduled broadcast time standards and requires one-half of a member station's programming to be cultural or educational. The NPR distributes programming through tape exchange and has leased 3.5 kHz bandwidth lines from AT&T to form a nationwide network of twenty-eight member stations. (2)

Recently, statewide educational television networks have been established or planned for many states in the U.S. These networks, in addition to distributing television programming, could also distribute low-bandwidth programming such as radio at marginal costs.

### 2.3 FM EDUCATIONAL RADIO

In 1946, when the FCC established the present FM (frequency modulation) commercial broadcast band, it reserved twenty 200-kHz channels (88 MHz to 92 MHz) in the FM broadcast band exclusively for educational use. These channels offer educators the opportunity to broadcast much higher-quality programming than can be broadcast over the AM broadcast channels. While each channel in the AM broadcast band is limited to a ten-kHz bandwidth (which corresponds to one channel of five-kHz bandwidth programming), each 200-kHz bandwidth FM broadcast channel can carry up to three channels of fifteen-kHz bandwidth programming. Thus, FM broadcast radio is able to distribute high-fidelity monophonic or stereophonic programming. In addition, due to FM's ability to trade bandwidth\* for noise immunity (2), FM radio is able to give noise-free reception over its prime coverage area. FM, however, is received in its prime coverage area only by direct propagation (that is, essentially along lines of sight from the transmitting antenna), which greatly limits its prime coverage area. This makes FM broadcast radio primarily a metropolitan service; reception over large distances requires sophisticated receivers and roof-top or tower-mounted antennas.

Due to the need to combat the high levels of man-made noise in metropolitan areas, the FCC finds "service may be provided by signal of

---

\*In AM broadcast radio, the ratio of channel bandwidth to program bandwidth is ten-kHz to five-kHz or 2:1. FM broadcast radio, on the other hand, with its three possible channels of fifteen-kHz bandwidth programming per 200-kHz bandwidth broadcast channel, has a ratio of channel bandwidth to program bandwidth of 200-kHz to 45-kHz, or 4.44:1. This higher channel bandwidth to program bandwidth ratio is responsible for FM's ability to provide relatively noise-free programming.

1 mv./meter or greater in metropolitan areas." (3) Table 1.1 lists the maximum power and antenna heights for the various FCC classes of stations, while Table 1.2 lists the prime coverage area which can be expected from each.

Table 2.1 lists the programming equipment needed for a typical FM broadcast studio, with equipment prices estimated where possible. As in Table 4 for AM, building costs (rent, heat, utilities, soundproofing, etc.) are not included. Table 2.2 summarizes typical transmitter costs for given power levels. Transmitting antenna prices are determined by the polarization and directional gain required, and vary from \$700 to \$18,000. (4) Tower costs (where applicable\*) run from \$100 to \$300 per foot of tower height, depending upon the condition and location of the antenna site, and upon any tower options desired. (5) The cost of the transmission line connecting the transmitter to the antenna varies from \$69 to \$173 per twenty foot section. (6) The cost of the audio channels (typically point-to-point dedicated microwave or Class AAA telephone lines) (8) needed to connect the studio to a remote transmitter and antenna varies depending upon the locale and distances involved; this cost has not been included. Table 2.3 lists typical personnel required.

## 2.4 AM EDUCATIONAL RADIO

### 2.4.1 Area of Coverage

The FCC defines the "primary service area" of an AM radio station as that area in which reception is not subject to objectionable fading or interference. (10) AM radio signals propagate both by groundwave

---

\*Because of their relatively small size, FM antennas can often be placed on existing towers; in this case, the cost of renting the tower space would be substituted for the cost of a dedicated tower.



Table 1.1  
Restriction of FM Transmitter Power  
and  
Antenna Height by FCC Class of Station (6)

<u>Station Class</u>	<u>Max. Power (Watts)</u>	<u>Max. Antenna Height (ft)</u>
A	3,000	300
B	50,000	500
C	100,000	2000
D	10	---*

---

\*As Class D stations are generally limited in audience to an institution (e.g., a college campus), no maximum antenna height or coverage figures can be given.

Table 1.2

Prime Coverage Radii and Area for FM Broadcast Stations (7)

<u>Transmitter Power (x 10<sup>5</sup> Watts)</u>	<u>Antenna Ht. (ft.)</u>	<u>Coverage Radius (miles)</u>	<u>Coverage Area (sq. mi.)</u>
5	500	14	616
50	500	33	3421
100	1000	48	7238
100	2000	65	12468

Table 2.1: Cost of Typical Educational FM  
Programming Equipment (8) (9)  
(1970)

	<u>Quantities</u>		<u>Total Cost (\$)</u>
	<u>Studio</u>	<u>Production Room</u>	
Microphones	2	4	450
Microphone Hardware			90
Audio Mixers	1	1	6400
Turntable with tone arm and cartridge	2	2	1400
Reel-to-Reel Tape Recorder	2	2	4000
Cartridge Tape Recorder	2	1	3400
Headphones	1	2	180
Monitor Amplifier	1		250
Speakers	2	2	500
Maintenance and Test Equipment			3000
			<hr/>
			Total \$19,670

Table 2.2: Typical FM Transmitter Costs  
Versus Output Power Level (9)  
(1970)

<u>Transmitter Output Power</u>		<u>Costs</u>		
1	kW	\$ 7870	+	\$ 200 for spare tubes
5	kW	\$15,745	+	\$ 531 for spare "
10	kW	\$20,995	+	\$ 661 for spare "
20	kW	\$28,345	+	\$ 767 for spare "
40	kW	\$64,950	+	\$1534 for spare "

Additional Transmitter Equipment Required (8) (9)

<u>Type</u>	<u>Cost</u>
Frequency Monitor	\$600
Mono/Stereo Modulation Monitor	\$1500/\$2500
SCA Frequency and Modulation Monitor*	\$1100
Multiplex Monitor **	\$500

\*Needed if station broadcasts SCA.

\*\*Needed if station broadcasts in stereo.

Table 2.3: Typical Personnel Requirements for  
an FM Educational Broadcasting  
Station (8)

<u>Type (full-time)</u>	<u>Number</u>	<u>Estimated Annual Salary (1974)</u>
General Manager	1	\$15,000
Chief Engineer	1	\$10,000
Programming Personnel	3	\$ 7,500 each
Announcers	3	\$ 7,500 each
Secretary/Receptionist	1	\$ 6,000

---

Note: Depending upon the amount and type of programming originated locally, additional full- and/or part-time personnel might be required.

propagation (over the electrical "line of sight" from the antenna), and by a phenomenon known as "skip" propagation (by bouncing between the earth's surface and the ionosphere). Groundwave propagation is not subject of "fading" - random signal level changes. Skip propagation, on the other hand, is subject to fading due to changing ionospheric conditions and due to multipath distortion.\* Thus, the primary service area of an AM station is limited to its groundwave coverage area.

Interference, the second term in the FCC definition, is caused by natural electrical phenomenon (e.g. lightning discharges) and by man-made electrical equipment (e.g. fluorescent lamps, automobiles, etc.) whenever energies in the AM broadcast band are created. Natural interference varies seasonally (there are more lightning storms in the summer than the winter), and due to the large amounts of energies involved, covers large regional areas, while man-made interference understandably is greater in densely populated areas than sparsely populated areas, and is generally local in nature due to the small amounts of energy involved.

The amount of interference is measured by the ratio of received signal strength to received noise. Signal strength can be computed by the equation  $S(\text{millivolts/ meter}) = A/r^2$ , where A is the signal strength in millivolts per meter (mv./meter) one mile from the antenna, and r is the distance from the antenna in miles. Noise interference,

---

\*If two or more parts of the wave follow slightly different paths to the receiving point, the difference in path lengths will cause a phase difference between the wave components at the receiving antenna. The total strength of the received signal will be the vector sum of the received components, and can be greater or less than any one of the individual wave components; they may interfere constructively or destructively with each other.

because it is unpredictable, is generally measured at the particular location of interest and an average value of noise is computed.

For year-round acceptable reception in rural areas (a good use for AM radio), the FCC states a minimal signal strength of 0.25 mv./meter is necessary. (11) This statement assumes that the average value of noise interference in rural areas is the same everywhere. From graphs supplied by the FCC (12), the prime coverages specified in Table 3.2 are available for the different classes of AM radio station as a function of soil conductivity. The average value of  $\sigma$  (the conductivity of soil in mhos per meter) is  $10^{-2}$  for moist soil and  $10^{-3}$  for dry soil. (13)

The coverage figures given in Table 3.2 are approximations of the prime coverage areas which can be expected for a given class of AM station and given ground conditions: the actual prime coverage area can be larger or smaller, depending upon local geography. Reception outside the given areas is possible, but reception becomes poorer as one gets further from the transmitting antenna(s). For educational radio purposes, coverage will be considered to be only the prime service area. Similar coverage figures can be derived for urban areas, but this will not be done in this report, as any broadcast radio services for urban areas could be provided by FM radio; FM radio, with its higher bandwidth and relative noise immunity, is preferred for providing broadcast audio services.

#### 2.4.2 Typical Costs for AM Radio

Table 4.1 lists the programming equipment needed for a typical educational AM broadcast studio, with equipment prices estimated where possible. Building costs (rent, utilities, soundproofing, etc.) are not included. As transmitter costs vary according to the power output of

Table 3.1

AM Power Restrictions by FCC License Class (12)

<u>Class of Station</u>	<u>Permissible Effective Radiated Power</u>
I	50 KW
II	10-50 KW
IIIa	1- 5 KW
IV	.25- 1 KW



Table 3.2

Typical AM Coverage Radii and Areas by FCC License Class (12)

		Conductivity of Soil (mhos per meter)	
		$10^{-2}$ (moist)	$10^{-3}$ (dry)
<u>Class of Station</u>	I	72 mi./10,286 sq. mi.	25 mi./1963 sq. mi.
	II or IIIa	65 mi./13,500 sq. mi.	22 mi./1520 sq. mi.
	IV	60 mi./11,509 sq. mi.	20 mi./1256 sq. m.

Table 4.1: Cost of Typical Educational AM  
Programming Equipment (8) (9)  
(1970)

	<u>Quantities</u>		<u>Total Cost (\$)</u>
	<u>Studio</u>	<u>Production Room</u>	
Microphones	2	4	450
Microphone Hardware			90
Audio Mixers	1	1	5000
Turntable with tone arm and cartridge	2	2	1400
Reel-to-Reel Tape Recorder	2	2	4000
Cartridge Tape Recorder	2	1	2750
Headphones	1	2	150
Monitor Amplifier	1		100
Speakers	1	1	150
Maintenance and Test Equipment			3000
			<hr/>
			Total \$17090

the transmitter, prices for several different levels of transmitter power are given in Table 4.2. Antenna tower costs range from \$100.00 to \$300.00 per foot, depending upon the location and condition of the antenna site. Note that multiple towers may be needed for directional antenna arrays.

The number of types of personnel which would be required to operate an AM educational radio station are largely dependent on the type of programming which is broadcast. Stations which broadcast mostly pre-recorded material such as music, syndicated news, etc., would not require the large production staff needed by stations that develop most of their own programming. A listing of the personnel needed to operate a typical AM educational radio station, along with their estimated annual salaries, is given in Table 4.3.

#### 2.5 COMPARISON: AM BROADCAST RADIO VS. FM BROADCAST RADIO

AM radio has one important advantage over FM radio. Comparison of Tables 1.2 and 3.2 shows that AM radio allows typically four times the coverage area of an equally powered FM station, making it more practical for rural service applications. Also since many more AM than FM receivers are owned, AM radio is able to be received by more people in most areas. This fact is especially significant in rural areas too far from population centers to normally receive FM.

Besides interference due to noise, which affects AM more than FM because of FM transmission's ability to trade bandwidth for noise immunity, AM radio has disadvantages which deserve mention in that they effect the utility of the medium for educational purposes. Unlike FM radio, which has specific frequencies reserved for educational use only, AM educational radio has to vie with commercial broadcast services for

Table 4.2: Typical AM Transmitter Costs  
Versus Output Power Level (9)  
(1970)

<u>Transmitter Output Power</u>		<u>Cost</u>
0.5	kW	\$5975 + \$ 209 for spare tubes
1.0	kW	\$6295 + \$ 209 for spare tubes
5.0	kW	\$21000 + \$ 805 for spare tubes
10.0	kW	\$22995 + \$1035 for spare tubes
50.0	kW	\$99950 + \$3880 for spare tubes

Additional Transmitter Equipment Required (8) (9)

<u>Type</u>	<u>Cost</u>
Frequency Monitor	\$990
Modulation Monitor	\$795

Table 4.3: Typical Personnel Requirements for  
an AM Educational Broadcasting  
Station (8)

<u>Type (full-time)</u>	<u>Number</u>	<u>Estimated Annual Salary (1974)</u>
General Manager	1	\$15000
Chief Engineer	1	\$10000
Programming Personnel	3	\$ 7500 each
Announcers	3	\$ 7500 each
Secretary/Receptionist	1	\$ 6000

---

NOTE: Depending upon the amount and type of programming originated locally, additional full- and/or part-time personnel might be required.

channel space. Moreover, the characteristics of AM detection (the process by which the information is extracted from the received signal) make AM more subject to adjacent channel interference than FM. If two different FM stations are received simultaneously by the same receiver, the stronger received signal completely covers the weaker of the two and only the stronger is received; this is called the "capture effect." When two stations are received on AM radio, however, both are heard. This interference problem is compounded by AM radio's ability to propagate by bouncing from earth to the ionosphere and back; during the night, longer distances are covered by this method so that an AM station which during the day receives no interference may at night receive objectionable interference. (FM's higher transmission frequencies eliminate this effect.) Thus, the FCC permits the major stations of a region to operate twenty-four hours per day, while lower powered stations serving only part of a region are restricted to operation only during the daylight hours when there is little chance of mutual interference. This is significant with respect to educational stations in that most adult continuing education would be carried in the evenings when its audience is at home. However, unless a powerful transmitter were available to the AM educational station, it would be required to shut down during the evening hours, eliminating any possibility of effective adult education. In addition, the low bandwidth of AM radio (5 kHz), while acceptable for speech, does not allow high fidelity music or stereo reception, which for educational purposes is not necessary but in some cases desirable.

AM radio also allows only one channel per transmitter, precluding the possibility of multiple programming from any one source. On the

other hand, FM broadcasters have been awarded the use of SCA (Subsidiary Communications Authorization) (1) channels allowing up to three programs to be transmitted simultaneously per station (i.e. stereo broadcast + one SCA channel, or monophonic broadcast + two SCA channels). SCA Programs cannot be received on conventional FM receivers, because FM receivers require a special adapter for SCA reception, but they offer a convenient format for transmitting programs to specialized audiences. Potential uses include education in the home, facsimile transmission of newspapers, and providing medical information to physicians. (1)

Summarizing, FM broadcast is superior to AM broadcast for educational radio services in all cases except those in which the required coverage area is so large that AM broadcast, with its greater effective service area, is the only practical solution.

### 3. BROADCAST EDUCATIONAL TELEVISION

#### 3.1 INTRODUCTION

Adding the visual dimension to educational radio, there were 220 educational television stations in the United States as of July, 1972 (14). Educational Television (ETV) can teach some subjects that cannot be taught over educational radio, due to radio's lack of graphic display capabilities. Some educators feel that the ultimate promise of television may be greater than that of radio for delivering effective educational programming: (15) comparison of the two media, however, have not always shown this to be true. (16)

#### 3.2 REGULATIONS

Very High Frequency (VHF) Television has been assigned twelve channels of six-MHz bandwidth by the FCC. These channels, which have been designated channels 2 through 13, are located in six-MHz frequency bands between 54 and 216 MHz, with gaps between 72 and 76 MHz and between 88 and 174 MHz (17). Of these twelve channels, a maximum of seven (channels 2, 4, 5, 7, 9, 11, and 13) may be used simultaneously in any region (18); this restriction guards against the possibility of interference between stations on adjacent channels. Ultra-High Frequency (UHF) Television occupies fifty-six, six-MHz channels (designated channels 14 thru 69) in frequency bands between 470 and 806 MHz. (17) While UHF television offers almost five times the potential number of channels that VHF does, due to practical problems discussed later, it will be shown that VHF channels are more desirable than UHF; this fact accounts for the low usage of the UHF broadcast band.

Table 5.1 contains the FCC restrictions on maximum antenna height and visual effective radiated power of the various channel assignments.



Table 5.1 Restriction of ERP and Antenna Height  
by Television Channel Assignment (20)

<u>Channel Assignment</u>	<u>Maximum ERP</u>	<u>Maximum Antenna Ht.</u>
2-6	100 kW (20 dbk)*	1000 ft.**/2000 ft.*
7-13	316 kW (25 dbk)	1000 ft.**/2000 ft.*
14-69	5 MW (37 dbk)	1000 ft.**/2000 ft.*

---

\*dbk = decibels above 1 kW power

\*\*For stations located in Zone I, which contains Illinois, Indiana, Ohio, West Virginia, Pennsylvania, Maryland, Delaware, Connecticut, Rhode Island, Massachusetts, and portions of Wisconsin, Michigan, New York, Vermont, New Hampshire, Virginia, and Maine. (21)

\*For stations located in U.S. and possessions outside Zone I.

Visual effective radiated power is defined as the power output of a station's visual transmitter (separate transmitters are used for the visual and audio portions of the broadcast signal), multiplied by the gain of the transmitting antenna. (19) To achieve gain in an antenna, the antenna is designed to focus power in some directions, while radiating little power in others. (An analogy to this is the reflector in a flashlight, which takes the relatively weak glow of a small light bulb and concentrates it into a powerful beam of light.) Thus a one kW\* transmitter feeding an omnidirectional antenna would have an effective radiated power (ERP) of one kW, while a one kW transmitter feeding a directional antenna with a power gain equal to 4 (3 db) would have an ERP of 4 kW.

Table 5 gives the maximum limit of coverage for various antenna heights assuming maximum ERP to the antenna. Unlike Tables 2.2 and 3.2 for FM and AM radio respectively, no coverage areas are given. This is because unlike the AM and FM cases where power limitations were on actual transmitter power output and antenna height, allowing calculation of the area of coverage as a circle whose radius was the limit of coverage, for a given ERP, a television station's area of coverage may or may not be circular, depending upon the characteristics of the antenna.

The maximum limit of coverage for UHF stations (channels 14 through 33) in Table 6 needs to be qualified as follows:

- 1) The limits of coverage given in the table are for the maximum ERP for the different channel

---

\*one kW = one kilowatt = one thousand watts.

Table 5.2 Minimum Field Intensity to be Provided Over Entire  
Principle Community Served in db. Above  
1  $\mu$ V/meter (dbu) (22)

<u>Channel Assignment</u>	<u>Minimum Field Intensity</u>
2 thru 6	74 dbu
7 thru 13	77 dbu
14 thru 69	80 dbu

Table 6. Maximum Limit of Coverage of Television Station by Channel Assignment and Antenna Height (23)

<u>Channel Assignment</u>	<u>Antenna Height</u>	<u>Limit Coverage</u>
2 thru 6	1000 feet	28 miles
2 thru 6	2000 feet	42 miles
7 thru 13	1000 feet	38 miles
7 thru 13	2000 feet	53 miles
14 thru 69	2000 feet	59 miles*

---

\*This figure may be misleading; see text.

assignments; for UHF, maximum ERP is generally achieved through the use of a transmitter equivalent in power to those used in the VHF bands, along with a highly directional antenna system. Thus, while the limit of coverage for UHF is larger than that for VHF, the area of coverage for UHF, due to the narrowness of the highly directional UHF antenna's beam, is smaller than that of VHF.

- 2) In its Rules and Regulations (23), the FCC notes that because this figure was gotten by graphic interpolation rather than field measurements, it is optimistic for distances greater than 30 miles, especially when considering interference from neighboring transmitters, so that actual limit of coverage will be less.

Summarizing, given maximum effective radiated powers for each channel assignment, VHF will generally have a larger coverage area than UHF broadcast services. Should broadcast educational services be widely used, lack of available VHF channels would force many of the stations to use the UHF bands.

### 3.3 COSTS

Table 7.1 lists the equipment and cost required for a studio capable of supporting four channels of educational television programming; required studio personnel, office staff, and their salaries, along with average programming costs are listed in Table 7.2. Representative costs for UHF stations (single channel) are given in Table 8. Table 9.1 lists other fixed costs associated with single channel UHF broadcast stations, while Table 9.2 lists annual operating (fixed) costs.

Table 7.1 Broadcast Television Studio Equipment and Costs (24)  
(1973)

<u>Quantity</u>	<u>Item</u>	<u>Fixed Costs</u>
6	Color cameras, broadcast quality	\$480,000
	Video-Audio Switching Equipment	\$150,000
2	2" Video Tape Recorders	\$240,000
4	1" Helical scan video tape recorders	\$ 40,000
1	Film/Slide Chain Equipment	\$112,000
	2 film cameras	
	2 film projectors	
	1 slide projector	
	Multiplexer Unit	
	Audio Equipment	\$100,000
	3 consoles	
	monitors	
	mike and speakers	
	Studio Lighting	\$100,000
1	Remote Pickup Van	\$350,000
	Includes 3 color cameras and a video tape recorder	
		\$1,572,000

Note: This studio is shared by four stations.

Table 7.2 Operational Costs for Broadcast  
Television Studio (24)  
(1973)

Wages and Salary

2 Shifts

2 Directors	\$ 12,000/yr.	\$ 24,000
6 Cameraman	\$ 9,000/yr.	\$ 54,000
6 Engineers	\$ 10,000/yr.	\$ 60,000
2 Light men	\$ 9,000/yr.	\$ 18,000
2 Audio men	\$ 9,000/yr.	\$ 18,000
2 Announcers	\$ 10,000/yr.	\$ 20,000

Fixed Costs

Office Staff

1 Administrator	\$ 10,000/yr.	\$ 10,000
1 Clerk	\$ 7,500/yr.	\$ 7,500
1 Accountant	\$ 10,000/yr.	\$ 10,000
	Total	\$221,500

Programming

Films and Tape Cost	\$174,000	
Artists (talent cost)	\$ 9,000	
Royalties and License Fees	\$ 57,800	
	Total	\$240,800

Variable Costs

---

Note: This studio is shared by four stations.

Table 8. Typical UHF Station Costs Including Transmitter,  
Tower and Antenna (25)  
(1973)

Probable Application	Power of Station	Tower Height	Approx. Radius of Coverage	Cost Per Average Station
Local	2kW	300 ft.	20 mi.	\$124,000
City	2kW	500 ft.	30 mi.	151,000
Metropolitan	10kW	800 ft.	40 mi.	280,000
Regional	9.2kW (avg)	350 ft.	25 mi.	202,000

Note: The added height with the same transmitter power increases the radius of the coverage. Added power at the same antenna height increases the signal to noise ratio (reduced interference) at a fixed distance from the antenna. Signal coverage is primarily line of sight (neglecting terrain) from the transmitting antenna to the horizon.



Table 9.1 Other UHF Broadcast Station  
Costs (Fixed Costs) (26)  
(1973)  
(Single Channel)

<u>Item</u>	<u>Cost</u>
Control Console	\$ 7,000
Input and Monitoring Equipment	\$18,000
Test Equipment	\$9,100
Spares	\$ 8,000
Building and Land	\$31,600
Installation	\$30,000
	<hr/>
	\$103,700

Table 9.2 Broadcast Station Annual Operational  
Costs (Fixed Costs) (26)  
(1973)  
(Single Channel)

<u>Item</u>	<u>Cost</u>
Engineer (5) 15,000/yr.	\$75,000
Technician (5) 12,000/yr.	\$60,000
Repair Parts	\$10,000
Building Maintenance and Utilities	\$ 1,800
Tower Maintenance and Utilities	\$ 2,000
Insurance	\$ 3,700
	<hr/>
Total for One Broadcast Station	\$152,500

### 3.4 FACTORS INHIBITING BROADCAST EDUCATIONAL TELEVISION

Since broadcast television is a service capable of bringing education into all homes in metropolitan areas, the problems limiting widespread use of educational TV must now be discussed. Unlike FM educational radio, which has specific frequencies set aside for its use, educational TV must vie with commercial broadcast stations for channel assignments. This would seem to be of little consequence considering the size and relative disuse of the UHF broadcast band. However, as discussed in Table 6, UHF television has less effective coverage area than VHF television due to the higher carrier frequencies used, making equal coverage more expensive if not impractical. In addition, most commercially available UHF tuners compound the UHF signal reception problem. They have poor adjacent signal selectivity, and they are harder to tune correctly, all but the newest being designed for continuous tuning rather than "click" tuning as in VHF.

The factors described make competition for the VHF broadcast channels in any area great, and have discouraged the use of the UHF broadcast band. Better UHF tuners are becoming available, but widespread use of these will take time. In the near future, use of the UHF broadcast band will remain light.

### 3.5 EDUCATIONAL TELEVISION NETWORKS (27)

Because television programming is more expensive to produce than radio programming, locally originated TV programming tends to reflect the aims of the organization holding the station license. In the major categories of license holders, programming on university-run stations tends toward public cultural enrichment, extension training

(especially in the case of land grant schools), student training and teaching, and public relations; stations run by public school systems concentrate on programming to assist their own staff. Locally originated programming, due to inexpert participants and lack of funds, is generally awkward compared to commercial programming, which typically budgets one hundred times as much for a given length of program.

To allow educational television stations to concentrate on producing several good programs per year rather than many programs of varying quality, six regional ETV networks have been formed. These network's members share production of programming and facilitate interstation exchange of ideas and cooperation.

The Eastern Educational Network (EEN) is the oldest, most prestigious, and perhaps the most successful of the regional networks. As of January 1970, it had twenty-five licensee members representing thirty-eight transmission stations in ten states and the District of Columbia; EEN's library of films and tapes held 891 instructional and 725 public television programs. Distribution within EEN is accomplished by private microwave, common carrier, and circulation of video tapes.

The Midwestern Educational Network (MET) had six affiliate members as of 1970. Its members are interconnected by microwave facilities that they own, and pay no "affiliation fee," but are instead paid by MET for carrying MET's program. One possible drawback to this system is that viewers might miss programming of value that cannot "pay for itself" due to the priority given to funded programs.

The Southern Educational Communications Association (SECA) was organized in 1967 to undertake almost any kind of cooperative activity which might prove to be necessary in educational communications. As

of January 1970, it had twenty licensee members with forty-eight transmitters in eleven states, making it the largest of the regional networks. Because SECA has appeared to some primarily as a pressure group for "the South", several Southern ETV stations do not belong. SECA has no interstate connections, but quite a few states within SECA have intrastate networks for program distribution.

The Central Educational Network (CEN) is the midwestern counterpart of EEN. As of January 1970, CEN had nineteen licensee members with thirty transmitters serving twelve states. Within CEN, program distribution is by mailing of videotape.

The Rocky Mountain Public Broadcast Network (RMPBN) receives nationally distributed ETV programs in Denver, Colorado, and along with programming produced regionally, feeds them to affiliates in the Rocky Mountain area over AT&T facilities. It is also possible to delay the transmission of programs from Denver to the various affiliates, allowing nationally distributed programs which are broadcast at times appropriate to the Eastern Time Zone to be shown when audiences in the Rocky Mountain area are most likely to see them.

The Western Educational Network (WEN) is a confederation of twenty stations, of which three are also in the RMPBN. Except for these three stations and the ETV station at Las Vegas, all members are located in California, Oregon, Washington, and Hawaii. Interconnection is via AT&T facilities, with station KCET (Los Angeles) acting as regional delay center; little cooperative programming and program exchange occurs within WEN.

A network to facilitate the exchange of quality educational programming nationwide was also formed. In 1954, National Educational Television (NET) was created as a service of the National Educational

Television and Radio Center (NETRC). While initially NET was conceived as an "exchange center" for programming produced by member stations, NET gradually got more involved in the production of educational programming for the general public, providing five hours of new NET programming per week to affiliates. Individual stations also draw upon NET's vast film and video tape library for additional programming.

In 1963, the Ford Foundation (which took over basic support of NETRC) announced the first of its six million dollar grants to finance the program service of NET. At this stage, NET turned over to other agencies its previous activities in educational radio and television station activation and welfare, concentrating all resources on one objective: a television programming service of substance and quality, to be provided to the American people through the nationwide network of noncommercial ETV stations affiliated with NET.

NET devotes at least half of its resources to programs in public affairs in an attempt to provide information, awareness, and to induce people to think critically about public issues. The rest of NET's programming falls into two categories: cultural programming and programs for children.

In 1967, as the result of a report of the Commission on Educational Television sponsored by the Carnegie Corporation of New York, President Johnson sent a proposal to the Congress calling for immediate action to extend and strengthen educational television, to increase federal support of public television, and to establish by act of Congress a new institution for public television. The resulting Public Broadcasting Act of 1967 included the creation of the Corporation for Public Broadcasting (CPB), a non-profit organization empowered to receive funds both from

government and private sources. CPB's role was specified as being to strengthen local public broadcasting stations, to develop (but not operate) an effective national interconnection of these stations, and to augment the national inventory of programs (but not to produce any programs itself).

In the early days of CPB, NET managed program distribution and live interconnection (on a limited scale) for CPB because CPB was forbidden to operate a network. Since November, 1969, however, when CPB created a new non-profit private corporation named the Public Broadcasting Service (PBS) to select, schedule, promote and distribute national programs to the country's noncommercial ETV stations, NET has concentrated on program production.

PBS is a user-controlled distribution system and is responsible to the stations it serves. Supported through private sources and CPB, its ten member governing board is made up of five members of local public television operations, two members chosen from outside the industry, and the presidents of CPB, NET, and PBS.

In January 1971, a survey conducted by PBS showed that fifteen states has completed interconnection of their ETV facilities. Of these fifteen, nine owned the network while the remaining six used either common carrier or private facilities. In many states, the network is multipurpose, being used for instructional television, medical education and experimentation, and public television distribution. Of the fifteen networks surveyed, Indiana had forty-three TV circuits and was capable of carrying ten simultaneous TV transmissions over the entire network, while nine of the states had only one video circuit. The total capital

Investment in state and privately owned facilities was over \$7 million, while the total annual payment for leased facilities amounted to \$4.05 million.



#### 4. INTERACTIVE MEDIA FOR EDUCATION

This section will discuss interactive communications media that are either presently providing educational services on a limited or experimental basis (e.g., PLATO IV and TICCIT) or could be used for providing educational services if made commercially available (the Bell System's Picturephone<sup>®</sup>).

##### 4.1 INTERACTIVE TELEVISION

While broadcast television can provide educational services at no charge to families having suitable receivers, such services have several limitations placed upon their effectiveness by the broadcast nature of the transmission system.

Educational programs are broadcast according to a fixed schedule. This limits such programs' effectiveness, in that although a program is of particular interest, parts of its potential audience might find it either inconvenient or impossible to view at the scheduled time. Also, since programs are broadcast to a mass audience, subject matter is limited to subjects having some degree of mass appeal.

Ideally, an educational system should have the capability to judge user comprehension and offer supplementary instruction to clarify points still puzzling to the user. Due to the one-way characteristic of a broadcast transmission system, this is difficult if not impossible to implement.

##### 4.1.1 TICCIT

The Mitre Corporation, in an effort to prove the effectiveness of education via television, has developed an interactive television system known as TICCIT. (28) Viewers can interact with the system by using a sixteen button pad or optional full alphanumeric keyboard

through which the viewer can select subject matter, answer questions and request supplemental instruction. Information transmission is done via coaxial cable.

A coaxial cable consists of a wire (center conductor) surrounded by a cylinder of dielectric which is in turn surrounded by a metallic sheath and an outer layer of insulation. Coaxial cable has two properties which make it desirable in wired transmission systems:

1) It has a nominal bandwidth of 300 MHz; that is, enough to carry fifty, six-MHz bandwidth television channels, 2) It is non-radiating, meaning that signals sent along a coaxial cable are contained on the cable and not radiated into space. This prevents interference to external signals.

There are two types of TICCIT systems under development: a system for the delivery of educational services within institutions (e.g., an electronic study center for a junior college), and a system for the delivery of interactive TV, including computer-aided instruction (CAI) into the home.

The TICCIT system for institutional use (29) has 128 terminals, each consisting of a color television screen, a full keyboard for interaction with the system, headphones for audio programming, and a digital video refresh memory (VRM). Programming is selected by interaction with the system computer and can include video tapes (each terminal can show video tapes up to 8% of the time), high-fidelity audio (the system includes random access audio storage with five hour capacity), computer generated graphics (graphic displays are made up of line segments upon a 200 by 256 line grid), and computer generated alphanumerics (up to seventeen lines of forty-one characters in seven colors).

Visual programming is to contain at least 92% still frames (i.e., alphanumeric or graphic displays containing no motion); these still frames could be displayed by the system several ways. First, as is done on broadcast television, the still frame could be repeatedly transmitted to the terminal for display. This would tie up 5 MHz of cable bandwidth for each terminal in use and require separate line and character generators for each terminal. TICCIT uses bandwidth more efficiently by a method which involves generating each required frame once and transmitting it to the appropriate terminal. At the terminal, the frame is recorded by the video refresh memory, then repeatedly played back until a new frame is required. Using this method, the cable and frame generation equipment are in use only 1/60 second for each new frame required, allowing the cable and the frame generation equipment to be shared among more terminals.

Interaction on TICCIT is accomplished quickly. When all 128 terminals are in operation, the key echo time, which is the time between the pressing of a key and the display of the character on the terminal screen, is 0.2 second. The courseware (computer control program) responds to interactive requests within 0.2 second. (30) System cost is outlined in Table 10.

While the interactive television system for institutional use would be solely used for educational purposes, to bring interactive television into the home requires a services package attractive enough that viewers would subscribe to it. Mitre is developing an experimental TICCIT system to deliver interactive services into the home through cable TV. In addition to educational services, the system could act as an information source, carrying employment and available social

Table 10. Costs of an Institutional TICCIT System\* (29, 30)  
(1974)

A. Courseware**	\$375,000/full semester
B. Staff and Spare Parts Replenishment	20,000/year
C. Hardware	
Main Processor (with 48 K core)	33,000
Terminal Processor	20,000
Card Reader	4,000
Line Printer	18,000
Magnetic Tape Unit	10,000
Moving Head Disc Control (2)	17,000
Moving Head Disc Drives (3)***	36,000
Fixed Head Disc Control (2)	7,000
Fixed Head Disc Drives (1)	5,000
CRT Terminal	3,000
Computer-to-Computer Link	2,500
Character Generator	7,000
Keyboard Interface	5,000
Vector Generator	11,000
Audio Response Units (20)	60,000
Audio Response Control & Switching	10,000
TV Sets (color) (128)	38,400
Keyboards (128)	19,200
Digital MOS Refresh Memories, Saturated Color, No Gray Scale (128)	112,000
Signal Processing Amplifiers (128)	32,000
Video Tape Players (20)	16,000
Refresh Control Electronics	10,000
TV Modifications	25,600
	Total
	\$501,700
D. Original Test Equipment and Spare Parts	\$20,000
E. Estimated Cost Per Courseware Student Hour	\$1.00

\*For the most part, these figures were obtained from Ref. 29. In some cases, due to change in system specifications or technological advances, more recent Mitre publications give different figures. In these cases, cost figures from Ref. 30 were used.

\*\*This figure is the development cost of a full semester CAI course; were the system to be mass produced, standard courses could be rented or purchased more cheaply from the supplier.

\*\*\*Of the three discs used by the basic system, one is used for system record-keeping, while the other two hold two semesters of courseware each. Should additional coursework capacity be desired, discs can be added to the system. Discs cost \$12,000.00 each.

services information, reviews of political candidates, instructions for income tax preparation, etc. It would also allow personal record keeping and automatic reading of utility meters.

The topology of a standard cable TV network (i.e., one used only to provide non-interactive programming) is shown in Figure 1. In this so-called "tree network", programming for the entire network is carried on a trunk cable which is shared among all the subscribers of the cable network. The repeaters spaced periodically along the trunk cable are amplifiers; they compensate for signal loss in the trunk and keep signals at levels suitable for good television reception. Customers are connected to the cable network by "tapping" the trunk cable and running a short length of small-diameter cable from the trunk to the customer's home. The tree configuration has the advantage of allowing an area to be wired for CATV services with the least amount of cable, and thus is the configuration most used in non-interactive CATV systems.

For a cable system offering interactive services, however, the tree configuration has a great disadvantage. Because of limitations in the frequency response of coaxial cable, the number of channels available on a cable are limited. In addition, the interactive services must share the available channels with standard broadcast programming. In the tree configuration, because all customers are connected to the system's headend through the single trunk cable, the few channels available for interactive services must be shared by all of the interactive subscribers. This generally limits interactive services on tree-type networks to polling of on/off switches and similar low data-rate services.

- HE** System headend
- R** Repeater
- H** Subscriber's home

Note: For clarity, most of the subscriber's homes and repeaters have not been illustrated.

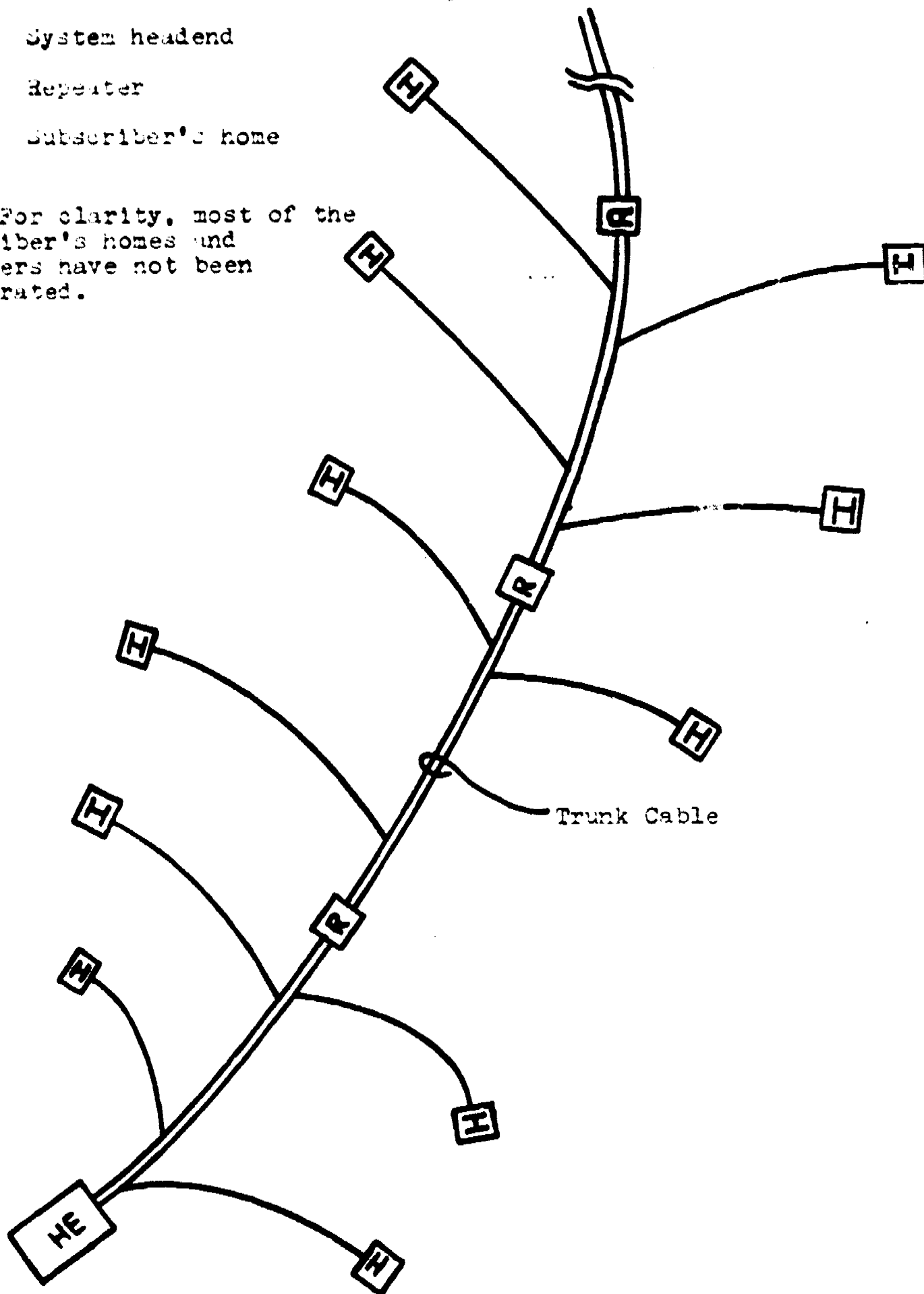

Figure 1. The Tree Configuration For Cable TV Networks

To make available to interactive users the full 6-MHz bandwidth needed for video transmissions, a cable configuration of the type shown in Figure 2, the hub configuration, is used to deliver TICCIT services. The headend of the system distributes all broadcast programming over the supertrunk to each hub within the system. At each hub, the cable network is further broken up into cells; each cell can be thought of as a small independent, tree-type cable system. The hub distributes the common broadcast programming to each of the cells; in addition, the hub contains a complete TICCIT computer system which supplies interactive services to the users within the cells. The chief difference between the two configurations is that while the one set of interactive channels available are shared among all of the system's subscribers in the "tree" cable configuration, each cell of the hub-configuration cable system has its own set of interactive channels. In this way, the number of subscribers being serviced by a set of interactive channels in the hub-configured cable system is reduced by a factor equal to the total number of cells within the cable system.

Each interactive channel has access at the hub to a VRM which comprises one of the output ports of the TICCIT computer. In this way, TICCIT users are not required to have individual frame grabbers in their homes, which would greatly increase user costs. Instead, they can share frame grabbers by sharing the available interactive channels. This sharing can cause problems, however, if too many users are assigned per cell, as excessive waiting lines for TICCIT services will develop.

- HE** System headend
- TH** TICCIT hub
- R** repeater
- H** Subscriber's home

Note: Most of the TICCIT cells, repeaters, and subscribers' homes have been omitted for clarity.

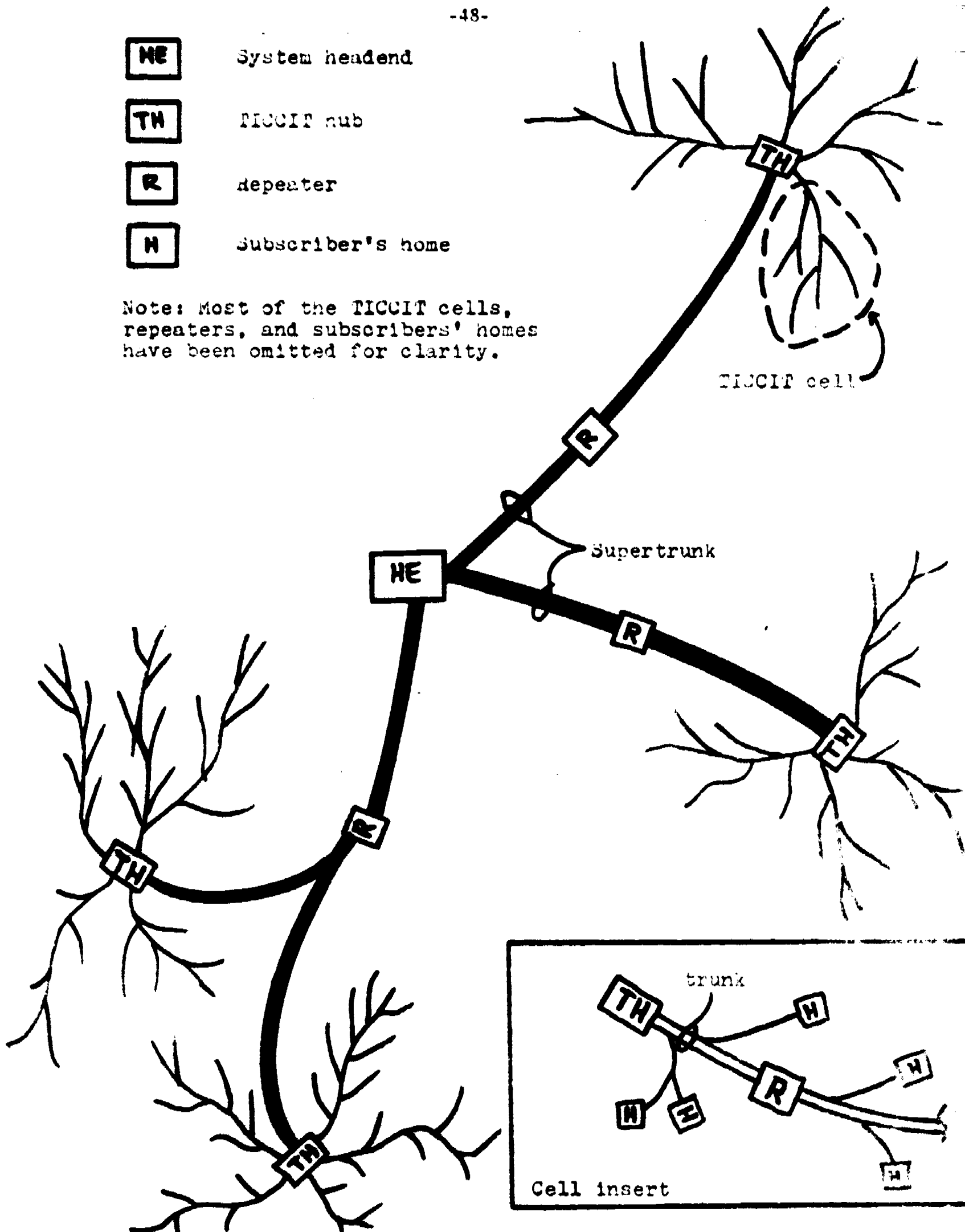

Figure 2. TICCIT Hub Configuration for Cable TV Network



In the design of any interactive system, the utilization of the limited service facility must be considered. Should too many terminals be assigned to the shared service facility, or should users attempt to utilize more service time than the system can supply, system users will receive "busy signals" too often and will have to wait excessively long before interactive service becomes available. This problem should be avoided; it detracts from the interactive system's main advantage over conventional information sources, instantaneous responses. Similarly, care must be taken to insure that the service facility is not underutilized; this would result in users having to pay excessive service fees to support the system.

Each cell of the TICCIT system proposed for Stockton, California (31) can be represented by the queueing model shown in Figure 3. The fifteen interactive TICCIT channels available per cell are represented by the fifteen servers in the model ( $N = 15$ ). These servers are available to the  $M$  TICCIT terminals serviced per cell. Should a user request interactive services at a time when all  $N$  channels are in use, the user enters a waiting line (first-in, first-out) and is assigned an interactive channel as soon as it becomes available. This is implemented in the proposed Stockton system by the TICCIT computer's ability to telephone waiting users to inform them that an interactive channel has become available. As each terminal's service requirement is satisfied, it returns to an idle state until a new service request is made; the TICCIT channel which supplied the service is made available to other users.

Assumptions concerning the system's operating characteristics made in the queueing model are as follows: 1) terminal idle times (the

BEST COPY AVAILABLE

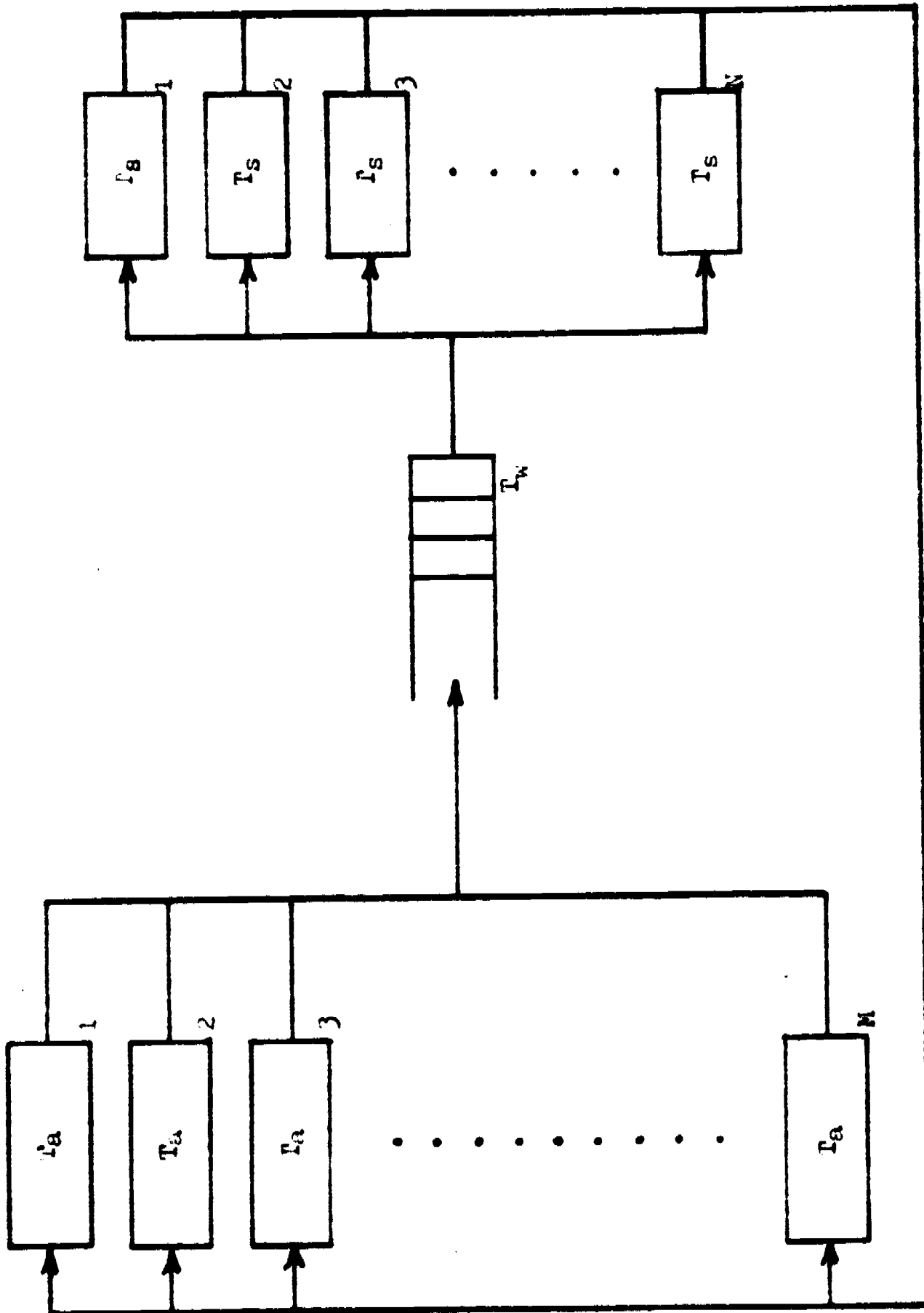

Figure 1. A multi-level bus of a multi-cell

times during which individual terminals are neither in use providing interactive services nor in the waiting line waiting for an interactive channel to become available) are exponentially distributed with a mean  $T_a$ , which is constant throughout the day. This assumption will sometimes give a conservative estimate of the probability of a user finding all TICCIT channels in use, as service requests are likely to be clustered rather than evenly distributed throughout the day. It is anticipated that there will be relatively few service requests during the morning and the afternoon, as many of the potential system users will be away from home because of jobs or school. During this period, the system will be relatively underutilized, and the probability of a user having to wait before receiving interactive services will be lower than average. Similarly, there should be a greater than average number of service requests during the evening, when most of the system's potential users will be at home. During this period, the probability of a user having to wait before receiving interactive services will be greater than average.

2) Servicing times are exponentially distributed, with mean  $T_s$ . The validity of this assumption is dependent upon the mix of interactive services offered; until "hard" data of actual system use is available, this is an appropriate queueing theory assumption. 3) The mean waiting time in the service queue is designated  $T_w$ .

The load factor for individual terminals,  $X$ , is defined as the mean fraction of time each terminal will use interactive service.\* For example, should each interactive terminal

---

$$* X = \frac{T_s}{T_s + T_a + T_w}$$

use an average of one-half hour of interactive services per ten hour period, the terminal load factor is 0.05. Similarly, the waiting factor, Y, is defined as the mean fraction of time users will wait for interactive services to become available.\* Given X and Y, the service ratio Z can be defined as

$$Z = \frac{\text{avg. time terminal idle}}{\text{avg. time terminal serviced}} = \frac{1 - X - Y}{X}$$

Denote by  $P_K$  the probability that K terminals are being serviced or are waiting for service. For  $1 \leq K \leq N$ , this means that K interactive channels are in use while  $N - K$  channels are idle. For  $N \leq K \leq M$ , all N interactive channels are in use while  $K - N$  terminals are waiting for service. If  $K = 0$ , no users have requested service and all of the interactive channels are idle.

Using queueing theory techniques, (32) the difference equations governing the  $P_K$ 's have been found to be

$$P_{K+1} = \begin{cases} \left( \frac{M-K}{N+1} \right) \left( \frac{1}{Z} \right) P_K & \text{for } 0 \leq K < N \\ \left( \frac{M-K}{N} \right) \left( \frac{1}{Z} \right) P_K & \text{for } N \leq K < M \end{cases}$$

With these equations, expressions for  $P_1$  thru  $P_M$  in terms of  $P_0$  can be found. The value of  $P_0$  can then be determined by the total probability law

$$P_0 + \sum_{K=1}^M P_K = 1.$$

---

\*  $Y = \frac{T_w}{T_s + T_a + T_w}$

Given  $P_0$ , the values of  $P_1$  through  $P_M$  can then be determined.

$L_w$ , the mean length of the service queue, can be calculated from the values of  $P_K$  by the relationship

$$L_w = \sum_{K=N}^M (K - N) P_K$$

The probability of a user having to wait before an interactive channel becomes available can be calculated as

$$\text{Prob (System Busy)} = \sum_{K=N}^M P_K = 1 - \sum_{K=0}^{N-1} P_K \text{ (by the total probability rule)}$$

The approach used here in calculating the various queueing parameters of the TICCIT model is as follows:  $M$ , the number of terminals per TICCIT cell;  $N$ , the number of interactive channels per TICCIT cell; and  $X$ , the terminal load factor, are specified as input data.  $Y$ , the terminal waiting factor, is initially specified as being zero, allowing approximate values for  $P_0$  through  $P_M$  to be determined. Given these values,  $L_w$ , the mean length of the service queue can be determined, allowing a new value for the waiting factor,  $Y'$ , to be determined from

$$Y' = L_w/M.$$

---

\*from queueing theory, (32)  $T_w = \frac{L_w (T_a + T_s)}{M - L_w}$

To convert this into an equation containing  $X$  and  $Y$ , normalize  $T_w + T_s + T_a = 1$ . Then  $T_s = X$ ,  $T_w = Y$ , and  $T_a = 1 - X - Y$ . Substituting,

$$Y' = \frac{L_w ((1 - X - Y') + X)}{M - L_w}$$

$$Y' = \frac{L_w}{M}.$$

This new value for the waiting factor,  $Y'$ , is then compared with  $Y$ , the value of the waiting factor used in the computations. If  $|Y - Y'| \leq .01Y$ ,  $Y$  is considered an acceptable estimate of the waiting factor and the queueing parameters computed with the waiting factor  $Y$  are used. If  $|Y - Y'| > .01Y$ , however,  $Y'$  is substituted for  $Y$  in the equations and the queueing parameters are recomputed. This iteration continues until a value of  $Y'$  such that  $|Y - Y'| \leq .01Y$  is found.

Figures 4 and 5 illustrate the effect of overutilization of the shared service facility upon the probability that users must wait before receiving interactive services. In Figure 4, the number of TICCIT terminals serviced per cell is varied while holding the per-terminal load factor constant at 0.05 (i.e., thirty minutes service per ten hours). It can be seen that the probability of a user having to wait for interactive services to begin is highly dependent on the number of terminals serviced per cell if the load factor is held constant; increasing the number of terminals per cell 11.4%, from 202 to 225 terminals per cell, increases the probability of a user having to wait before receiving interactive services from 0.10 to 0.20, a 100% increase. Further increases in the number of terminals serviced per cell cause the probability of having to wait for interactive services to increase even more sharply. Figure 5 shows that similar results can be caused by increasing the per-terminal load factor excessively; this could happen, for example, if system designers did not anticipate the user demand resulting from a particularly attractive services package.

In the proposed TICCIT system for Stockton, California, 1000 terminals will be distributed among the six cells of the system, giving a nominal terminal density of 167 terminals per cell. The waiting

Figure 4. Waiting Parameters For TICCIT System Versus Number of Terminals Per Cell

(15 channels per cell,  
load factor = 0.05)

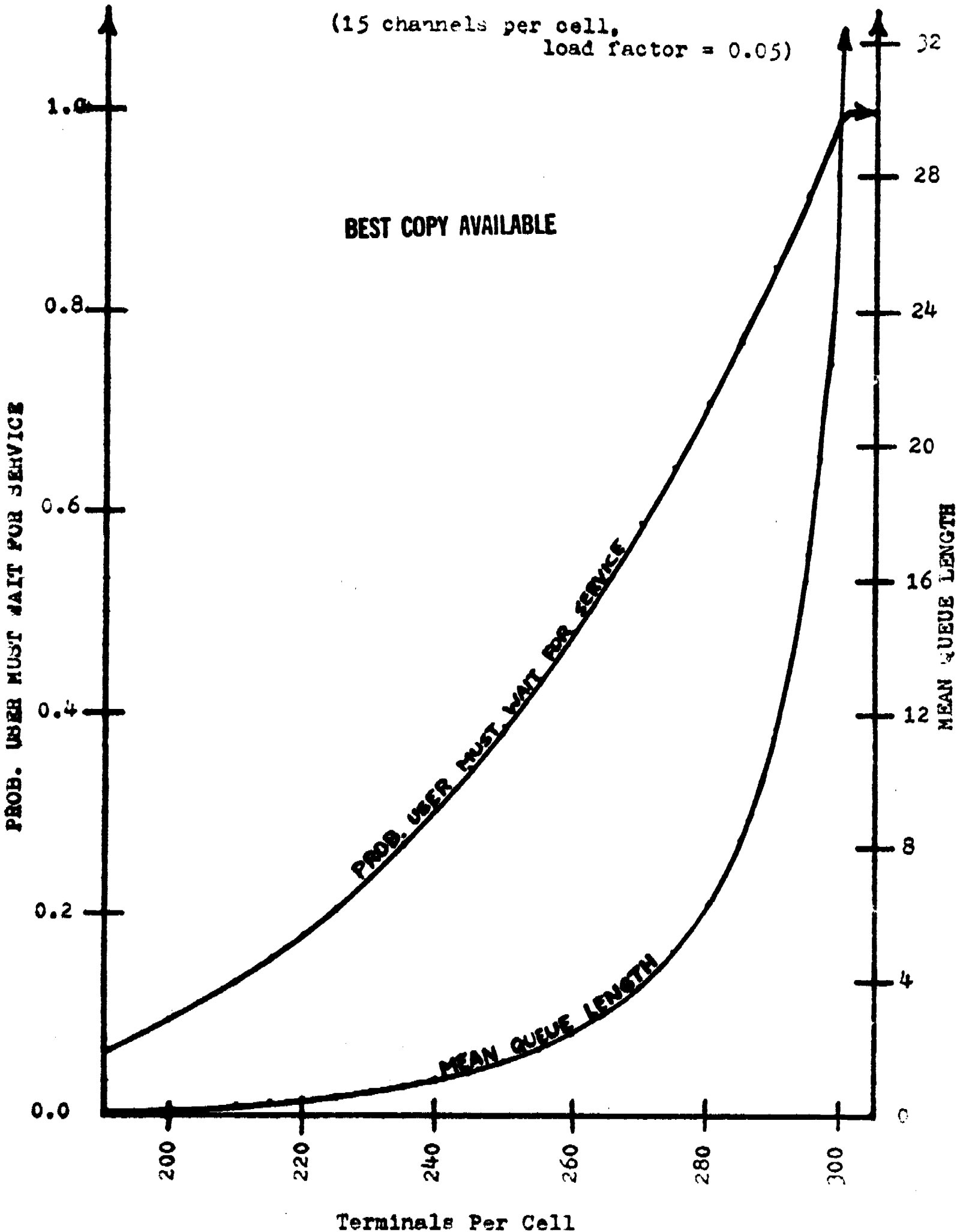
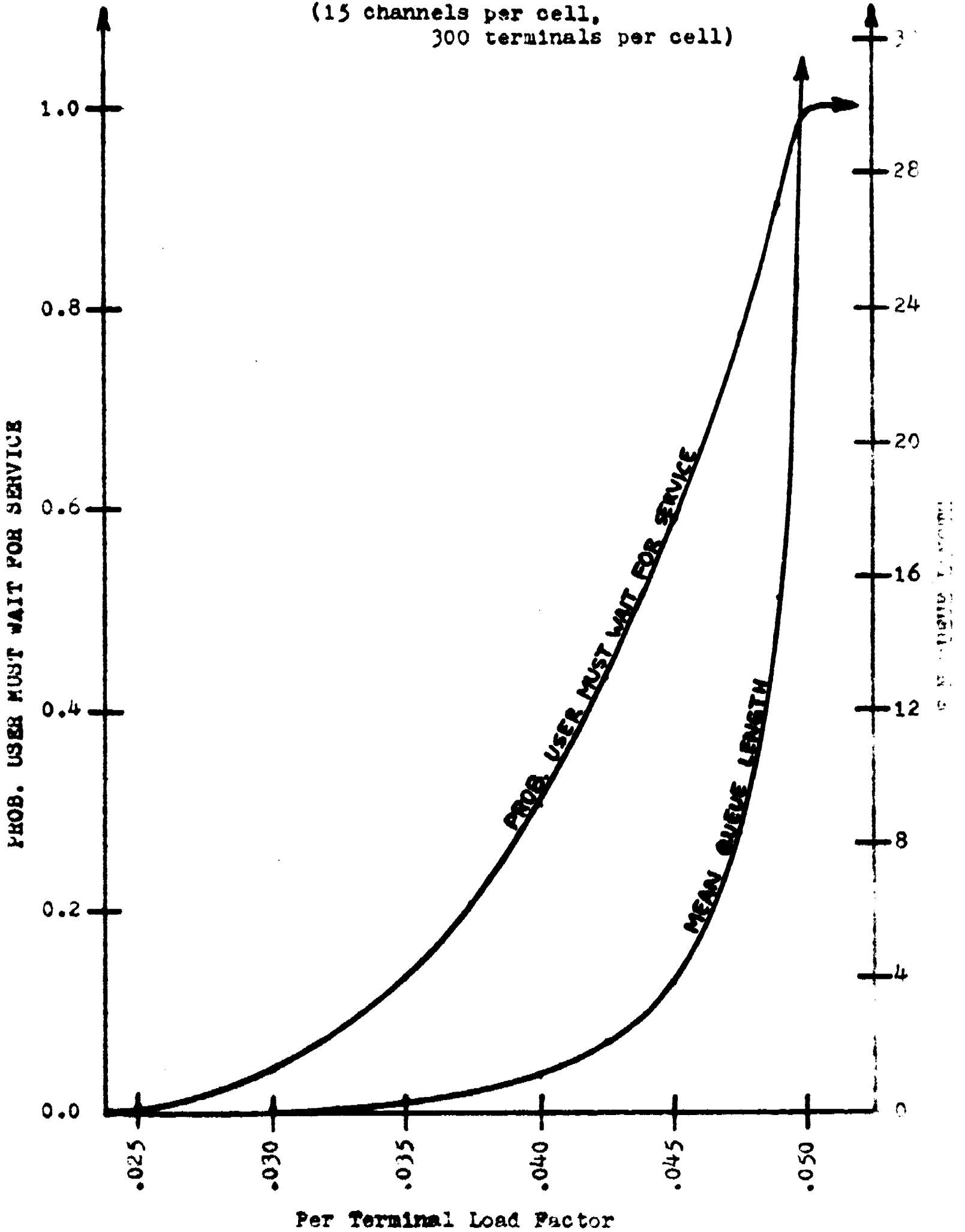

Figure 5. Waiting Parameters For TICCIT System Versus Per Terminal Load Factor

(15 channels per cell,  
300 terminals per cell)





parameters for this terminal density are illustrated in Figure 6. It can be seen that given a terminal load factor of 0.05 (i.e., each terminal receiving an average of thirty minutes of service per ten hours), there is a 2.4% chance that a user will have to wait before receiving interactive services; the mean length of the service queue will be 0.26, implying that the mean percentage of time users will spend waiting for interactive services equals .016%\*, a nominal wait for service which is unlikely to greatly disturb customers. Nevertheless, the waiting parameters are very sensitive to changes in the load factor: by increasing the load factor to .06 (thirty-six minutes service per terminal per ten hours), the probability of having to wait before receiving interactive service is increased to 9.3%; for a load factor of 0.65, the probability of having to wait before receiving interactive service is 16.0%. This sensitivity to small changes in the load factor would seem to indicate that some congestion might develop during the evening hours, when a greater than average rate of requests for TICCIT services is expected.

Should the price of suitable video refresh memories\*\* be reduced from the 1973 price of \$875 per unit (30), it would become more feasible for heavy users of TICCIT services to have individual video refresh memories in their homes. Since the TICCIT system would then only need send each still frame once to these VRM - equipped TICCIT subscribers, each VRM - equipped TICCIT subscriber would require use of the interactive

---

\*as discussed previously,

$$Y' = \frac{L_w}{M} = \frac{.026}{167} = 0.00016$$

\*\*Digital MOS Storage, Saturated Color, no Grey Scale.

Figure 6. Waiting Parameters For TICCIT System Versus Per Terminal Load Factor

(15 channels per cell,  
167 terminals per cell)

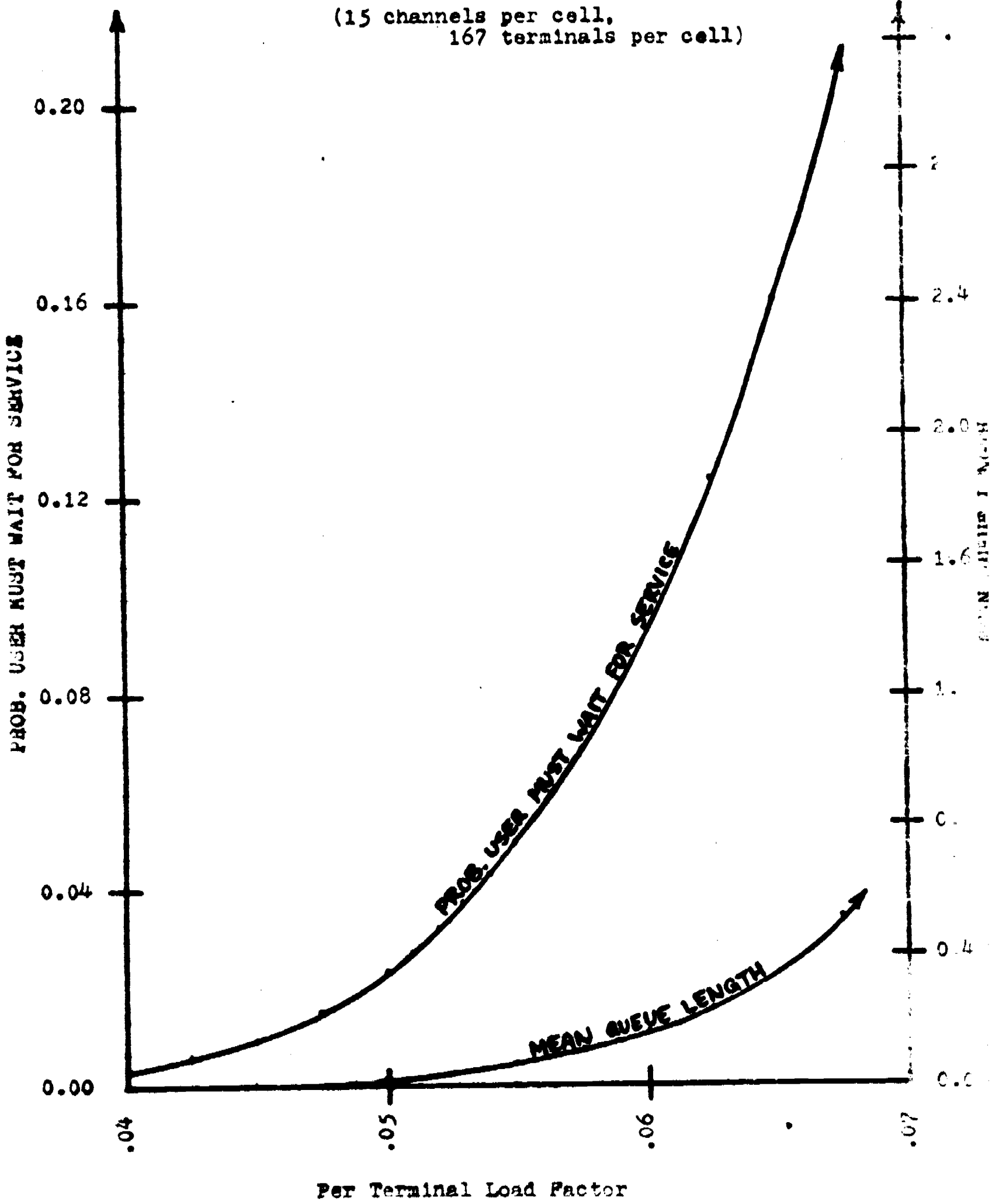

channel only occasionally for a fraction of a second while receiving service; this would allow a single interactive channel to be shared by many interactive users simultaneously, greatly increasing the service capacity of existing TICCIT systems. A likely prediction is that in the future, if TICCIT services become highly accepted and the price of VRM's is reduced, TICCIT systems will be changed from the proposed centrally refreshed topology\* to a combination central refresh/individual refresh topology. This could be augmented by reserving several of the interactive channels in the future for use by TICCIT subscribers having their own VRM's; the remaining interactive channels would be equipped with VRM's at the hub and would be used by subscribers not requiring enough TICCIT service to justify the cost of an individual VRM.

Table 11 presents a summary of the equipment costs for the proposed TICCIT system. It should be noted that the prorated cost of the system hardware is about \$1100.00 per home terminal, exclusive of user-owned television sets. Note that in considering hardware costs when comparing the cost of a TICCIT interactive cable system to a conventional tree-configuration non-interactive system, the cost of laying the extra cable required for TICCIT's hub-configured cable network must also be considered.

To aid in projecting required customer revenues, the MITRE Corporation has developed an economic model of the TICCIT system called ICEEM.\*\*

---

\*i.e., shared VRM's located at TICCIT hubs only.

\*\*Interactive Cable Economic Evaluation Model. (28)

Table 11. System Equipment Costs (31)  
(1974)

Computing System	\$229,825
Video System, Audio and Video Interface	381,660
Home terminals (1000)	400,000
Analog Storage	20,000
Spares	30,000
Test Equipment	20,000
Computing Supplies (Tapes, Discs, and Paper)	16,000
Telephone Parts*	10,000
Trailer, shielded with air conditioning and raised floor	40,000
Total	<u>\$1,147,485</u>

---

\*Equipment is used to establish a telephone data link from the Stockton TICCIT system to the Mitre Corporation's headquarters in Virginia.

In the model, physical characteristics of the cable system, such as required length of cable needed to be laid above- and below-ground, number of headends and cells, etc., and system penetration characteristics for both non-interactive and TICCIT services are specified as input data.\* By further specifying the percentage of the TICCIT system cost to be financed by loans to the system builder and the loan interest charges, the model is able to predict cash flows and determine user charges for one way and TICCIT interactive services that will allow the system owners to make a suitable profit.

In the analysis of a hypothetical model for a system serving a section of Washington, D.C., a total of 26,680 households are passed by the cable. (28) Assuming an 8% interest rate on borrowed capital,\*\* which finances 80% of the TICCIT system, the following monthly service charges were required to return a 30% gross yearly return on equity.

For basic one-way (non-interactive) services:

Average Penetration	Monthly Service Fee**
30.62%	\$9.33
61.23%	\$5.78

For TICCIT interactive services:

Average Penetration	Monthly Service Fee**
19.14%	\$24.23
38.27%	\$19.51

---

\*System penetration refers to the percentage of households potentially able to be serviced by the cable system who actually subscribe.

\*\*Recently, the prime interest rate has been as high as 12 1/4%, while inflation has been 10.7% for the latest 12 month period, (33) rather than the 3% yearly inflation presumed in the model. Thus, the service fees derived by the economic model are conservative.

Thus, assuming that each terminal receives one-half hour of TICCIT services daily, TICCIT services may cost the user as little as \$1.30 per hour.

#### 4.1.2 Picturephone<sup>®</sup>

Another approach which could be used for interactive educational television is the Bell System's Picturephone<sup>®</sup>. By reducing the number of picture elements\* per frame (251 lines per frame with 211 picture elements per line (34)), each Picturephone<sup>®</sup> channel employs a ~~one-~~ MHz bandwidth rather than 4.6 MHz bandwidth for broadcast quality frames. For the accompanying audio channel, standard telephone bandwidth (2.8 kHz) is used.

Because design emphasis was on face-to-face viewing for business usage, the desk-top display unit includes a 5 x 5.5 inch television display, self-contained camera, and concealed speaker. (35) Attached to the unit by a cable is a standard Touchtone<sup>®</sup> telephone and a control unit with controls to adjust camera field of view, brightness, audio volume, and an on/off selector. A "Vu-self" selector allows the operator to adjust his camera field of view, and a privacy selector disables the operator's camera. Audio privacy can be had by using the telephone's handset.

For face-to-face usage, the normal field-of-view at thirty-six inches from the camera is 17.5 x 16 inches. (35) The field-of-view can be electronically zoomed\*\* to 28.5 x 26 inches for wide-angle

---

\*For a discussion of video resolution, bandwidth, and picture elements (pels), see Appendix A.1.

\*\*This is accomplished by varying the portion of the camera's vidicon tube which is scanned. For wide-angle viewing, the entire vidicon target is scanned; for "normal" field of view, only a portion of the vidicon's target is scanned. This method of varying the field-of-view does not affect the resolution of the received picture. (36)

viewing, and by a hinged visored mirror, a 5.5 x 5 inch area of text or pictorial information can be viewed. The display resolution is such that standard type can be viewed with marginal clarity (this feature is important in business applications, so most Picturephones<sup>®</sup> in use today have been modified to provide better resolution\*). (37)

Interaction is accomplished through the use of the twelve button Touchtone<sup>®</sup> pad on the telephone or on an optional full keyboard available from Bell Telephone for computer interaction. To make a Picturephone<sup>®</sup> call the # key on the Touchtone<sup>®</sup> pad is pressed before the telephone number is entered. Calls can also be made from a Picturephone<sup>®</sup> to standard telephones.

In spite of reducing the bandwidth to 1 MHz, transmitting the 1 MHz signal over ordinary twisted pairs is difficult, requiring twisted pairs in very good condition that are "conditioned" by inserting "equalizers" at one mile intervals. Equalizers are special repeaters that have frequency dependent amplification to compensate for the greater attenuation given higher frequencies over twisted pairs. Even so, at distances over six miles, noise becomes a major problem in the higher frequencies. (34)

To combat noise, within a six mile radius each Picturephone<sup>®</sup> signal must enter a switching center. Here, signals to Picturephones<sup>®</sup> within the six mile radius local area are routed appropriately in analog form, while signals to be routed outside the local area are digitally encoded

---

\*RCA Global Communications has marketed a desk-top slow-scan tranceiver called Video-voice capable of sending broadcast-quality video stills over ordinary telephone lines. It cannot, however, transmit or receive real-time video.

into a 6.3 Mbit/sec series of pulses. To accomplish this encoding, the one MHz signal is first sampled at a rate slightly greater than twice its highest frequency; in this case, in excess of two million samples per second. Each sample is then quantized; that is, a decision is made as to which of several prespecified values the magnitude of the **sample** is closest, and the sample is assigned a value corresponding to that level.

Each sample value is then converted into a string of digital bits, a series of electrical pulses with values of either 0 or 1. To represent a sample which was set equal to one of  $n$  values,  $\log_2 n$  bits are required. Thus, two million samples per second, each quantized into one of eight levels, results in a binary signal whose bit rate is nominally  $(2 \times 10^6) \times \log_2 8 = 6$  Mbit/sec. This representation of a signal by binary pulses is called pulse code modulation (PCM).

The PCM signal can be sent over distances greater than six miles without excessive deterioration due to noise. This is because as the binary signals are regenerated along their transmission path at each binary repeater, the accompanying noise is removed. To remove the noise, a binary repeater samples its received input at intervals coincident to the message's pulses, decides if each pulse is a "0" or a "1", and retransmits a new noise-free pulse. No matter how far a Picturephone<sup>®</sup> signal is to be sent outside its local area, it remains in digital form until within six miles of the receiving unit, where it is reconverted to analog form. Analog signals cannot be "cleaned up" as digital signals can.



Except at the edges of viewed objects, most visual scenes change gradually in greyness from pel\* to pel, and the signal representing the difference in greyness from pel to pel tends to have smaller values than the Picturephone<sup>®</sup> signal itself. Because of this, the signal that is digitally encoded for long distance transmission by Picturephone<sup>®</sup> is this difference signal; the representation of an analog signal by digital bits representing signal differences is called differential pulse code modulation (DPCM).

In addition to improving system noise performance, because DPCM reduces signal redundancy,\*\* less information need be sent to reconstruct a given quality signal; this results in a decrease in signal bandwidth. While an analog Picturephone signal would displace about 300 audio telephone channels on a long distance trunk cable, the DPCM signal displaces only 96 audio telephone channels, a saving of cable bandwidth, but also an indication of the relative cost of Picturephone<sup>®</sup> when compared with audio telephone rates.

Presently, Picturephone<sup>®</sup> service is available only in Chicago and Pittsburgh. In Chicago, where prices are low to promote subscription to Picturephone<sup>®</sup> service, there is a monthly charge of \$75.00 per month covering only local and intercom (i.e. intra-office) use. The Picturephone<sup>®</sup> may be used for local calls up to thirty minutes

---

\*Picture element; see Appendix A.1

\*\*That is, signal groups do not have to be unnecessarily repeated. For example, a uniform grey shade, corresponding to the fifth video quantization level, would be represented in PCM by repeatedly generating 101 (the binary code for 5). In DPCM, however, the uniform grey shade would be transmitted as one three-bit code representing the difference between the shade of the previous pel and fifth quantization level grey; the remaining codes would all be zeros, corresponding to no change in shade from pel to pel. This represents a large reduction in the amount of video information the channel must carry.

Table 12. Picturephone<sup>®</sup> Hardware Costs (38)

For intercom use only (i.e. intra-office)	\$1620/unit
For intercom and local use only	\$4369/unit
For intercom, local, and long distance use	\$13,989/unit

---

Note: The increase in cost for local and long distance services reflects the additional telephone plant transmission capacity required per Picturephone<sup>®</sup> unit.

per month with no additional charge; after that, billing rates are \$.15 per minute. (38)

Rates for Picturephone <sup>®</sup> service in Pittsburgh are double those of Chicago, and are said to be equivalent to those Bell Telephone would charge were Picturephone <sup>®</sup> in wide use. (38) Thus, were Picturephone <sup>®</sup> to be used for interactive educational television services one-half hour per day, thirty days per month, monthly service charges would be \$411.00 for the Picturephone <sup>®</sup> communications channel. If the channel could be shared by subscribers as is done in the TICCIT system, the resulting lower monthly user costs would be more practical for education users.

Table 12 lists hardware costs per unit for Picturephone <sup>®</sup> service. We have seen that given the present system configuration, Picturephone <sup>®</sup> is not competitive with TICCIT for interactive educational television purposes. In addition, as with a 5.5 x 5 inch field of view, text legibility is marginal, the display screen and/or resolution would have to be improved before Picturephone <sup>®</sup> was suitable to transfer large amounts of alphanumerics. Note that the figures in Table 12 are for presently available units, and do not take into account either future technology or economies of scale.

#### 4.2 COMPUTER-AIDED INSTRUCTION (CAI)

##### 4.2.1 The PLATO System

Unlike the TICCIT system for CAI, which uses small computers and television terminals to provide instruction for local users, the University of Illinois' PLATO system employs a large central computer and innovative display technology to provide versatile computer-aided instruction to large numbers of terminals. By sharing system costs among a large number of users (up to 4000 terminals), and by utilizing

the versatility of the large scale computer, the designers hope to offer high quality instruction at costs equivalent to those of elementary education, typically 35-70¢ per hour. (39)

The use of a large general purpose computer allows versatility in teaching methods unavailable in systems using smaller computers. In addition to programmed instruction, PLATO has the capacity to perform simulations (constructed by the courseware author or the student), allowing dynamic display of concepts which might be difficult or impossible to explain using still frames. The student may also call on the computational powers of the large general purpose computer to speed calculations; this capacity broadens the subject matter able to be taught by PLATO. Finally, because communication between terminals is possible, students can play games or request help, using the system as a communications medium.

Another advantage of the PLATO system is that school districts wishing to experiment with CAI may acquire several PLATO terminals for the incremental terminal cost only. This is not possible with the TICCIT CAI system, because the 128 terminals that the TICCIT computer supports must be located close to the TICCIT computer (29); a school district wishing to experiment with TICCIT CAI would have to purchase or rent a complete TICCIT system if a system with unused capacity was not available in an adjoining school district. PLATO's 4000 terminal capacity, however, required that the system be able to service terminals located at great distances from the system's computer; otherwise, a user-base capable of supporting a 4000-terminal system might not be available. Therefore, PLATO CAI terminals can be had for the cost of the terminal, plus the cost of the transmission line(s) to the central PLATO computer and the incremental cost of running the system. The

incremental system cost includes the use of the existing courseware on the PLATO system, whose authoring costs are likewise divided among the 4000 terminals able to be serviced.

For educators wishing to write their own courseware, the TUTOR authoring language was developed for PLATO (40). After several\* hours of familiarization with the language, educators who have not had any prior computer programming experience can write their own courseware. Unlike the TICCIT system, on which courseware can be written only when the system is idle, (29) courseware can be written from any PLATO terminal without affecting the operation of the other terminals.

It is beyond the scope of this paper to fully describe the workings of the PLATO system. The following sections will discuss PLATO's central computing facility, student terminal hardware, and data transmission system, considering their effect on user cost.

#### 4.2.1.1 The Central Computer Facilities

In order to determine the best ways to use computers in education, three successive and increasingly flexible systems (PLATO I, II, and III) were designed and built at the University of Illinois. As a result of experience with these previous systems, the specifications of the central computing facility for the 4000 terminal PLATO IV system were developed. It was found that to service 4000 terminals so that no student experiences noticeable delay requires that the central computer have two million words of extended core memory and 64K to 128K of high speed memory in the central processing unit, have an execution time of four instructions per microsecond, and be capable of transmitting

---

\*The language's authors claim users can write parts of useful lessons after a one-hour introduction to TUTOR. (40)

significant data were incorporated in the specifications of the central computer facility for PLATO IV.

Several commercially available large computers can perform about  $4 \times 10^6$  instructions per second. Thus, even if the number of computer instructions per student per second were increased to 2000, these large scale computers require an average processing time of only 500  $\mu$ sec/request. To insure fast system response time, a safety factor of two was allowed; thus the system can accept 1000 requests per second. The safety factor of two implies the computer will be idle 50% of the time on the average; such time can be used for batch processing,\* reducing interactive user costs.

Data from the PLATO III system indicated an average request rate of one request per four seconds per terminal. (41) Thus, the central computer can service 4000 terminals allowing an average of 1 milli-second of computer execution time per request.

The expected waiting time,  $E(w)$ , that elapses before the computer (single channel server) will accept a given student's request is given by queueing theory (41) to be

$$E(w) = \frac{\rho^2 + \lambda^2 \sigma_t^2}{2\lambda(1-\rho)}$$

where  $\lambda$  = system request rate =  $\frac{0.25 \text{ request/sec}}{\text{terminal}} \times 4000 \text{ terminals}$

$$= 1000 \text{ requests/sec}$$

$\sigma_t$  = execution time standard deviation

$$= 500 \times 10^{-6} \text{ sec}$$

$$= 500 \text{ } \mu\text{sec}$$

---

\*Non-interactive computer service which requires the user to leave his program for the computer operator to run when computer "time" becomes available (i.e. when the computer is otherwise idle).

$E(t)$  = execution time expected value

= 500  $\mu$ sec/request

$\rho = \lambda E(t) = 0.5^*$

These values give an expected waiting time ( $E(w)$ ) of 500 microseconds. Assumptions made were that student input arrival times are Poisson distributed (a reasonable assumption for 4000 independent student terminals), and that the request rate probability density function expressed as a function of the computer time required to process the particular request type is approximately exponential (PLATO statistical records substantiate this). The probability  $P(w)$  that a student must wait a time  $w$  or longer before being served by the computer is given by (41)

$$P(w) = \rho \exp [-w(1-\rho)/E(t)]$$

The probability that a student will have to wait 0.1 second or longer is very small.\*\* This fact implies that the probability of the request queue building up or of noticeable delay in processing student requests is negligible.

In previous usage of the PLATO III system, each student has needed to be assigned 300 words of dedicated extended core memory, although the various teaching strategies used had required up to 600 words to be assigned per student. Allowing an average of 500 words per student, 4000 terminals would require the central computer to have two million (sixty-bit) words of extended core storage. (42)

---

\*This figure is implied by the safety factor of two mentioned previously; the server (computer) is in use an average of 50% of the time.

\*\* $.5 \exp (-100) = 1.86 \times 10^{-44}$ .

Data from PLATO III indicated that twenty percent of the computer instructions used in processing student requests referred to the 500 words of dedicated student storage. Therefore, the central computer must be capable of quickly transferring data between the slower extended core storage and high-speed core memory. Such a transfer can be done by some existing computers at a rate of  $10^7$  words per second (41), so the data could be transferred between memories in 50  $\mu$ sec., which is small enough to avoid objectionable delay.

To allow for storage of lessons (1k to 2k words per lesson) and for the various teaching strategies, the central processing unit of the computer should be sufficiently large (65k to 128k words). The peak data rate from the computer to each terminal is limited to 1200 bits per second; this allows data transfer to the terminal to be accomplished over telephone lines.

To service 4000 terminals, data would have to be buffered out of the computer at a maximum rate of 4.8 million bits per second, which is within the present state of the art. (11)

The PLATO IV system, as it currently exists at the University of Illinois, is only able to service about 1000 terminals, rather than the 4000 terminals the system was designed to service. There are two reasons for this; both reasons are related to the use characteristics of the present developmental system. First, experience with PLATO III had indicated that each terminal should be assigned an average of 500 words of extended core storage. Thus, two million words of extended core storage (ECS) would be sufficient to serve 4000 terminals. The estimate of 500 words of ECS per terminal, however, assumed that terminals would be distributed in groups of thirty-two terminals each



data at 4.8 million bits per second. Several existing computers (e.g. the CDC Cyber 70 in use in the present PLATO IV system)\* meet these requirements (41).

From the experimental data from the PLATO III system, it was found that the rate of computer instructions used in processing the student's requests (i.e. the number of instructions per second per student) remained relatively constant. It was independent of the student's level of learning, the teaching strategy being used, or the course content of the lesson material. For example, in simple drill and practice programs, the students make requests frequently (approximately one request every four seconds on the average), but the processing of each request is rather simple.

In more complex teaching strategies, however, the student must do more thinking and planning between requests, while the system has to execute more instructions to process each request. The resulting product of computer instructions needed to process each request times the number of requests per second remains nearly constant at about 300-500 computer instructions per second per student.

Data from the PLATO III system also indicated that each student terminal requires 300-500 words (60 bits/word) of dedicated computer memory space. Output rates from the computer for each student terminal ran at approximately ten alphanumeric characters/sec. (or 60 bits/sec), but peak transmission demands required rates of at least 1200 bits/sec. Input rates to the computer per terminal were between two and five bits/sec., but required a peak rate of 60 bits/sec. These and other

---

\*Jack Stifle, personal conversation, September, 1974.

group of thirty-two terminals would form a CAI classroom in which all of the students using the terminals would study the same courseware. Because at least thirty-two terminals would be using the same courseware simultaneously, the amount of ECS needed to store the courseware would be divided among the thirty-two terminals, reducing the amount of ECS used to store courseware per student by a factor of thirty-two. The terminals of the present PLATO IV system, however, are mostly distributed as single terminals or in groups of two or four, and generally the terminals within a group are used independently of each other; each terminal is used to study different courseware. Because of this, an average of 2000 words of ECS is required per terminal.\* Thus, two million words of ECS can service only 1000 terminals.

Were this the only problem caused by the present system's use characteristics, 4000 terminals could be serviced if an additional six million words of ECS were added to the system. Because of the smaller groupings of terminals, however, more courseware authoring per terminal than was anticipated has occurred. Because authoring requires five times the number of computer operations per second that studying existing courseware at a terminal does\*, the central computer facility of the present PLATO IV system will be fully utilized during the day by 1000 terminals, rather than fifty-percent utilized during the day by 4000 terminals. Attempting to add more terminals to the system would result in unacceptably long system response times.

Summarizing, due to the user characteristics of the present PLATO IV system having placed a heavier than anticipated load upon the

---

\*Jack Stifle, personal conversation, September, 1974.

the system's central computer facility, the system is able only to service 1000 student terminals, rather than the 4000 terminals the system was designed to service. A side effect of this is that the present system is not available for batch processing during the day, while seventy-five percent of the system's computing capacity is available for batch processing during the night.

#### 4.2.1.2 The PLATO Student Terminal

Unlike the TICCIT system, whose 128 terminal capacity limits service to local applications, PLATO IV, with its 4000 terminal capacity must be able to service terminals over large areas; otherwise its capacity, should service be limited to local terminals, could be utilized only in urban areas. To avoid the necessity of laying regional coaxial cable networks to service PLATO terminals, the data rates from the computer to each terminal have been limited to 1200 bits per second; this allows data distribution to be done over existing voice-grade telephone lines. (41)

This low data rate, however, would greatly limit the versatility of courseware that could be presented over the PLATO terminal if conventional visual display techniques were used. To avoid this, several innovative audio-visual devices for the student terminals were developed at the University of Illinois. Computer-generated dynamic displays are presented on a plasma display panel, a device combining inherent memory, display, and high brightness in a potentially inexpensive fabrication. This new device consists of two sheets of glass separated by a layer of ionized gas. Rows of transparent electrodes are deposited on the outside of each glass panel, with the electrodes on one panel perpendicular to the electrodes on the other panel, providing at each apparent intersection a point that can be

selectively illuminated. Once illuminated, each point remains illuminated until it is extinguished; this eliminates the need for a video refresh memory at each terminal. Furthermore, as each point in the 512 x 512 line display is selectively addressable, the display can be modified without retransmitting the full display. These features of the plasma display panel allow dynamic displays at the low costs and low data rates. (42)

Because the plasma panel is transparent, static photographic information projected onto a translucent screen behind it can be superimposed upon the dynamic computer-generated display. This is accomplished through the use of a random access image projector. (43) The image selector provides for the random access selection of any image from a possible 256 color images arranged on a 4 x 4 inch film sheet with a worst-case access time of .4 seconds. Each image is assigned coordinates corresponding to its row and column in the film plane. Individual slides are selected by a set of four pneumatic cylinders for each axis mounted in series which control the film sheet's position. (For details of the mechanical structure of this device, see Appendix A.12).

To provide high quality randomly-accessed audio messages to remote user terminals, a pneumatically controlled audio system is being developed. (43) Audio messages are recorded onto a disc of plastic magnetic recording material, typically twelve inches in diameter. The messages are recorded on 64 successive circular tracks of 300° with each track divided into thirty-two, one-quarter-second message units. This disc is then mounted upon a rpm-driven turntable of high moment of inertia with an angular velocity of one revolution per eight seconds. The use of half-track heads, allowing two separate audio tracks to be recorded per disc track, allows up to seventeen minutes of

audio to be recorded upon each disc, any portion of which may be selected with a worst-case access time of 0.4 seconds. (See Appendix A.2 for details).

Each PLATO IV student terminal consists of a plasma panel with random-access image selector, a key-board, and a controller whose outputs can control the random-access audio system or other hardware. These terminals should be able to be produced within the cost limits of \$1500 to \$3000 each, depending upon quantities produced and optional accessories provided. (44) It should be noted that current production costs amount to \$5300 per student terminal.

#### 4.2.1.3 Communications Network

As was mentioned previously, the peak data rate to a PLATO student terminal has been limited to 1200 bits per second; this allows the use of voice-grade (3 kHz) telephone lines to transfer data to and from the central computer facility. The interstate tariffs for leasing these voice-grade lines vary with location, but can be considered to be approximately \$4.50/mile/month. (45) The communications costs of using these lines for a system the size of PLATO over the long distances which might be needed to get enough users to fully utilize PLATO's 4000 terminal capacity in some areas might be prohibitive. For example, assuming a student terminal 100 miles from the central computing facility received data via voice-grade telephone line, this would cost \$450.00 per month or \$2.81 per student contact hour,\* a figure almost an order of magnitude above the target cost per student contact hour.

In areas where the service is available, an attractive alternative to voice-grade telephone lines is the use of cable television (CATV)

---

\*Assuming 160 student contact hours per terminal per month.

**BEST COPY AVAILABLE**

to distribute the data from the central computer. By arranging the outgoing data in a prescribed format, a single CATV channel could carry data from up to 1000 student terminals, enough to provide CAI services for entire metropolitan areas. The communications channel between the PLATO computer and the CATV system's headend could consist of either dedicated cable or microwave.\*

Outgoing data from the PLATO central computer is formed into a signal which is compatible with standard broadcast television equipment; this allows CATV operators to distribute PLATO signals without special equipment. Broadcast television signals in the United States consist of thirty frames per second, each frame containing 525 lines. To reduce visual flicker, each frame is divided into two fields of 262 1/2 lines each, with sixty fields being transmitted per second. Of the 262 1/2 lines per field, the vertical blanking interval (the interval during which the cathode ray tube's electron beam returns from the bottom of the screen to the top of the screen) consumes up to 21 lines, leaving a maximum of 241 1/2 lines per field to be used for video, or in the case of CAI, binary data transmission.

PLATO divides each of the 242 lines used for data transmission into equal time bins of  $6.35 \times 10^{-8}$  sec each. (45) The first 16 bins are required for horizontal synchronization and blanking (so that standard television equipment can be used). The remaining 84 bins per

---

\*Dedicated cable would be adequate for short runs; to send PLATO data to a cable system in another city, however, the majority of the distance would be covered by microwave point to point relay normally used by the cable operator to bring distant television to the system headend. This would be required as the coaxial cable used in most systems have a maximum effective service length of 15 miles due to the noise buildup caused by the analog repeater amplifiers used within the system to compensate for loss within the cables. (10)

line each contain a bit of digital information, giving a data rate of  $1.2096 \times 10^6$  bits per second.\* Thus each TV channel can be used to supply data to 1008 PLATO student terminals at a rate of 1200 bits per second. The data from the central computer is fed to a signal composer, along with television synchronization and blanking signals. These are formed into a composite baseband signal which is RF modulated onto a carrier for the proper television channel and distributed over the cable television system.

Each PLATO CAI classroom receives the appropriate data from the cable through a PLATO IV site controller, which can service up to 32 terminals. (47) The receiver contained within the Site Controller, after extracting the data, converts it to audio frequency shift keying (AFSK, a form of modulation which represents binary zeros and ones by two different audio frequency tones) for transmission over ordinary voice grade telephone lines to individual terminals. Each Site Controller also contains equipment to combine the return keyset information for up to 32 terminals onto a single voice-grade line for transmission back to the computer center.

It would seem reasonable that if it is more expensive to distribute data from the computer to the PLATO student terminals by CATV rather than single telephone lines, the same should be true for the data returning from the student terminals to the central computer facility. This approach is impractical for several reasons.

The majority of CATV systems in existence today are of a unidirectional nature; that is, as the amplifiers used to compensate for

---

$$* = \frac{60 \text{ fields}}{\text{seconds}} \times \frac{240 \text{ lines}}{\text{Field}} \times \frac{84 \text{ bits}}{\text{Line}}$$

signal loss in the system amplify only in one direction, most CATV systems could not provide a return signal path. The economy of using CATV systems for data distribution is contingent upon using existing facilities whose expense is shared by other users.

For CATV to be cost-effective in transmitting CAI data in the PLATO system requires the television channel bandwidth to be shared among many terminals. This would require a parallel to serial data transformation; i.e. while the computer sends out data to each terminal in a prescribed order, so that none of the data overlaps, the responses from the terminals occur at random times, which can overlap and interfere with each other unless they are first stored and rearranged in a prescribed, non-overlapping order. To be thus rearranged requires that all data be brought together in one location for conversion, a task which is partially done in each local CAI classroom but must be presently done over long distances by voice-grade telephone lines.

To service individual remotely located student terminals, a receiver unit identical to the receiver used in a Site Controller is placed at a convenient location along the CATV cable. (47) Data is transmitted from the receiver to each of up to 32 remote terminals by individual voice grade telephone lines, and another voice grade line carries keyset information back to the central computer facility from each terminal.

The ultimate penetration of CATV (percentage of the U.S. population receiving CATV services) has been estimated between forty and sixty-six percent. (48) Millions of homes will then be wired over to utilize data from centralized sources, forming a ready-made market for services like those offered by the PLATO IV CAI system.



#### 4.2.1.4 Costs of the PLATO IV System

A large, general purpose computer able to meet the requirements of the PLATO IV system costs approximately 4.5 million dollars; 2.5 million dollars for the mainframe of the computer and 2 million dollars for the two million words of memory and the input/output equipment required. An estimate for the system software, including some course development programming, is an additional 1.5 million dollars. The total, six million dollars, amortized over a period of five years, yields a cost of 1.2 million dollars per year. (41)

Assuming that the 4000 terminals system will be fully utilized 8 hours per day, 300 days per year, there are approximately 10 million student contact hours per year. Thus, the hardware costs of the system, excluding terminals, are 12¢ per student contact hour.\* If PLATO's equipment costs are to be made comparable to that of an elementary school's classroom, 27¢ per student contact hour, the terminal costs must be limited to 15¢ per student contact hour, or \$1800 per terminal amortized over five years. Present indications are that this terminal cost, for a terminal consisting of a plasma panel with driver, a keyset and random-access slide selector, will be difficult to meet. An estimate for the cost of PLATO terminals produced today, even in lots of 1000, was \$5300.\*\*

For PLATO IV's equipment costs to be limited to 27¢ per student contact hour, the assumption that the system would be fully utilized 8 hours per day, 300 days per year was made. (41) The validity of this

---

\*If the system can only service 1000 terminals, as discussed previously, the hardware costs for the system, excluding terminals, are 48¢ per student contact hour.

\*\*Jack Stifle, personal conversation, September 1974.

assumption can be challenged in several ways. First, queuing theory dictates that any unscheduled system will seldom be fully utilized due to the excessive waiting time for service (in this case, access to a PLATO terminal) that users would experience in a fully utilized system. By specifying that CAI use would be scheduled, this objection can be countered, but such scheduling would limit one of CAI's principal advantages - the ability to instruct individually at any time. However, the scheduled CAI system would remain much more convenient than traditional learning situations with respect to flexibility of scheduling.

The system utilization assumption also implies that enough diverse and attractive courseware is available so that a user-base large enough to fully utilize the system exists. While a large portion of this user-base might be consist of students receiving CAI in subject traditionally taught in schools, to attract enough "non-students" to fully utilize the system the rest of the time would require large amounts of courseware in specialized subjects. Because this specialized courseware might have less mass appeal than courseware in the traditional subjects, its effect on cost per student contact hour should be considered.

Alpert and Skaperdas (41) compute the cost of courseware for PLATO IV in the following way: experience on the previous PLATO systems has shown that preparing a good CAI course is roughly equivalent in effort to preparing a good textbook, for which most authors receive a 10-15% royalty rate yielding them approximately 80¢ per student. Thus, assuming a cost of \$1.20 for royalties, reproduction, and distribution, courseware for a forty-hour class adds 3¢ to the system cost per student contact hour. Simenson and Renshaw (49), on the other

hand, state that estimates of instructor preparation time per hour of CAI courseware range from 40 to 200 hours preparation time per hour courseware for various CAI systems, with an average cost of \$1000 per hour courseware. If this developmental courseware cost estimate is accepted, 33,000 students must use the courseware before the cost per student contact hour for courseware is reduced to three cents. The implications for courseware is non-traditional specialized subjects are obvious, and are strengthened by the fact that courseware written for one CAI system generally cannot be transferred to another type of CAI system without extensive recoding and debugging. (49)

The data distribution costs for a system the size of the PLATO IV are highly dependent upon the population density of the regions receiving CAI services. To service metropolitan areas already wired for CATV, the CATV system could serve as the distribution network within the city; a leased or dedicated microwave channel would be required to transmit PLATO data between cities. Metropolitan areas not wired for CATV might use a UHF television channel for local data distribution; in either case, data from PLATO terminals in cities distant from the PLATO computer would be collected in the city via telephone lines, given a parallel-to-serial transformation by a mini-computer, and sent to the PLATO computer via another microwave channel.

To distribute PLATO CAI services to large areas of low population density, a communications satellite channel might be used for data distribution; low cost ground terminals with provisions for the return transmission of terminal data would provide CAI services to towns within the service area. Because of the number of network options possible for distribution of PLATO data, the determination of PLATO IV data

distribution costs are beyond the scope of this paper. However, a study with this objective in mind is presently underway at the Center for Development Technology.

## 5. LIBRARY AND DOCUMENT TRANSMISSION SERVICES

This section will deal with techniques used to transmit documents over a communications network: facsimile ("fax") and slow scan television (SSTV). Several existing systems permitting the remote inspection of literature through interactive terminals will also be discussed.

In recent years, libraries have faced continuing problems caused by tight budgets, increasing materials' costs, and particularly, the ever-growing volume of new materials which are published each year.

Communications technology might help solve these problems through resource sharing and electronic distribution of materials. Interactive communications networks would allow easy access to materials contained in remote libraries, permitting individual libraries to reduce the amount of seldom-used materials stored locally by increasing reliance on interlibrary loans. Also, because individual libraries utilizing communications networks could serve larger geographic areas, libraries could achieve economies of scale and greater support bases. Finally, electronic distribution techniques would permit widespread use of microfilm storage of library materials, resulting in a great reduction of needed storage space and a savings of some of the money presently spent in handling materials (e.g., staff salaries for restacking books, keeping user records, etc.).

Library patrons could receive materials over interactive terminals by slow-scan television (SSTV), with the option of ordering hard copies, either full size or microform, from facsimile terminals. Moreover, at remote terminals with memory, temporary electronic storage of library materials would allow nighttime servicing of requests for large amounts of materials. This facility would increase the apparent capacity of the

communications network. For example, an audio cassette recorder modified to be controllable from the system's head-end could be remotely activated during the night when the requested materials were available. It would record the incoming SSTV signal on an audio cassette, and would be remotely deactivated at the end of the SSTV transmission; the library material would then be available for viewing the next morning. With proper terminal equipment, one audio cassette can store up to 325 frames of marginal resolution (1000 lines/frame) or 80 frames of high-resolution (2000 lines/frame) SSTV, the choice of resolution depending upon user requirements. (See Appendix A.1 for a discussion of resolution).

### 5.1 FACSIMILE

Facsimile refers to any system capable of transferring alphanumeric or graphics by electro-optical means, generating hard (i.e., paper or microform) copy at the receiving location. Teletype and similar systems employing keyboards and alphanumeric printers are not included.

The principles of facsimile are much like those of television, in that the document to be transmitted is scanned opto-electronically, and an analog signal waveform corresponding to areas of light and dark on the document is generated. This waveform may then be transmitted over a communications network to the receiving station, where a writing head, carefully synchronized in speed and phase to the reading head, reconstructs the original picture.

#### 5.1.1 Facsimile Transmitters

The heart of the facsimile transmitter is the scanning head, a photo-sensitive device which generates an electric current proportional

to the amount of light striking it. Thus, when the scanning head, equipped with a lens system so that the head "sees" only a point, is moved across an illuminated document, a signal is generated corresponding to the light and dark areas along the line which the head scans. By scanning a series of adjacent parallel lines across the document, a signal proportional to the light and dark areas in the document is constructed.

There are two types of devices which are primarily used in scanning heads. (50) One, the electron photomultiplier tube, is constructed so that light striking a target generates electrons. These electrons are then directed through a series of dynodes, elements within the tube which have the property of emitting more electrons than they receive from the adjacent emitting elements. This property results in great amplification of the original electron stream. Because of their great sensitivity, photomultipliers are used when half-tone rendition (i.e., correct gray shading), in addition to black and white, is necessary. The photomultiplier tube has the disadvantages, however, of being relatively expensive, fragile, and requiring very high power supply voltages for operation.

For facsimile units which are to be used only for transmitting alphanumeric and line drawings, as is the case for most business uses, the half-tone rendition capabilities of the photomultiplier are unnecessary. In these units, the scanning head often contains a photo-transistor or photodiode, solid-state devices which are not sensitive enough to provide half-tone resolution, but are inexpensive, rugged, and work with low supply voltages.

Facsimile transmitters are classified according to the method by which scanning is accomplished. In the revolving drum method of facsimile, the document to be scanned is wrapped around a drum and secured by a clip running the width of the drum. The drum is then revolved at a constant speed, allowing the scanning head to scan a line across the document. To allow the head to scan the whole document, the head is either moved smoothly over the width of the drum, or the head is held stationary and the revolving drum is moved axially so the head "sees" the whole document. The signal generated by the scanning is processed and can be fed into an appropriate communications network.

In another system, the flat-bed system for facsimile, the document to be transmitted is drawn vertically past a slit which is scanned horizontally by the reading head; that is, in the flat bed system line scan is accomplished by scanning head movement while in the drum system line scanning is accomplished by drum rotation. The main advantage of this system is simpler operation than the revolving drum system, as the operator has only to feed the document into a slot in the side of the facsimile transmitter. Since the mechanism is enclosed within the casing of the unit, there are fewer maintenance problems due to dirt and accidental damage. In addition, unlike the revolving drum method, the vertical size of the document able to be transmitted is not physically constrained, allowing odd-sized documents such as photographs of fingerprints, etc., to be transmitted.

Document scanning in the flat bed system is done by a stationary photosensitive device placed at the center of a wheel containing several lens systems (see Figure 7). Each lens is adjusted so that it focuses the light reflected from a point along the exposed slit into the



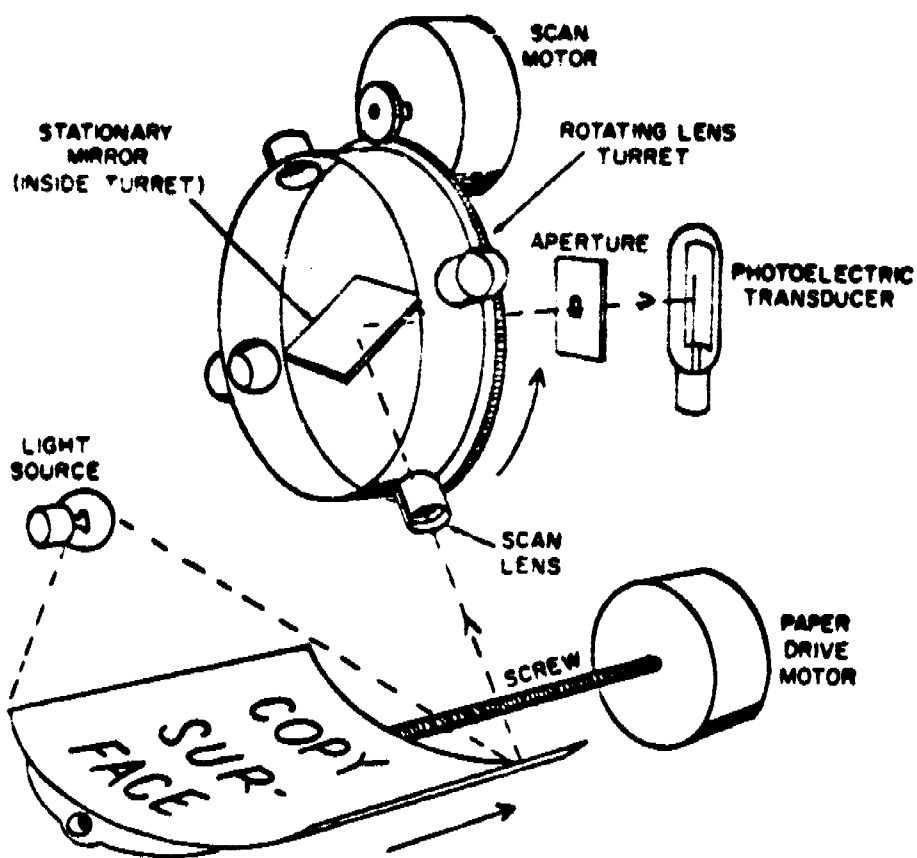

Figure 7. Document Scanning Mechanism For the Flat Bed System of Facsimile (50)

-90-

photosensitive device. Line scanning is accomplished by rotating the wheel at a constant rate; as the wheel rotates, each lens in turn "sees" a point traversing a line of the document exposed through the recording slit.

As each lens system reaches the end of the slit, it leaves the view of the photosensitive device and is replaced by the next lens system on the wheel; in the meantime, the document has been drawn forward so the next lens system "sees" a new line on the document. In this manner, the document is sequentially scanned without requiring the scanning head to retrace quickly at the end of each line, as is done in a cathode ray tube.

The signal resulting from optical scanning of the document, after being processed for best reception over the particular communications network used (typically voice-grade telephone lines) and being transmitted, is received by the facsimile receiver and must be transformed to hard copy before it is available to the user. This task is accomplished by a writing head at the receiver scanning a piece of paper in the same sequence as the transmitter scanned the original document. The writing head marks on the paper where the transmitted signal indicates a dark area was being scanned. (Some facsimile receivers include a switchable inverter allowing either positive or negative images of the original to be recorded at the receiver.) By this means, the entire document is reassembled at the receiving point.

For the received document to be of acceptable quality, the receiver must be in correct time and phase synchronization with the facsimile transmitter. (50) For example, if the receiver is operating at a faster scanning rate than the transmitter, each subsequent line in the received

document will be displaced horizontally. In a reproduction of a typewritten document, as each line of type will be reproduced by approximately four scan lines, the typed lines and individual letters will be at best slanted; at worst, the received document will be illegible.

Phase synchronization refers to the receiver writing head's relative position along the scan line with respect to the reading head of the transmitter. For example, should the writing head be in the middle of the scan line when the reading head is at the beginning of the scan line, the reassembled document would have the original document's margins in the middle of the sheet, the left portion of the original on the right side of the received image, and the right portion of the original document on the left side of the reproduction.

To maintain time synchronization between units, each has a crystal derived time base. The design exploits the crystal's property that it will oscillate stably at one frequency, which is determined by its physical dimensions. By putting matched crystals in the time base of both the transmitter and the receiver, both have a standard from which the scan rate can be synthesized. (50)

To accomplish phase synchronization, the transmitter generally sends out a series of pulses corresponding to the scanning of the margin for a period of time before beginning the scanning of the document. At the receiver, a system of brakes interrupts scanning until the receiver is scanning the margin at the same time that the transmitter is. At this point, the facsimile transmission begins.

Because crystals are temperature sensitive, the scanning rate of the receiver and transmitter will never be exactly the same. For normal length documents, while some drift, along with the corresponding

phase shift, will occur, it will be so small over the time required for the document transmission (typically six minutes for a standard sized page being facsimiled over a voice-grade telephone line) as to have negligible effect. When a very long document is facsimiled without periodic resynchronization, as is possible with the flat-bed transmitter, however, the phase error would be cumulative, possibly resulting in an unacceptable transmission. For this reason, while a flat-bed facsimile transmitter may be used to transmit odd-sized documents which could not be accommodated on a revolving-drum machine, there is a practical limit to the maximum document length which may be transmitted without resynchronization.

#### 5.1.2 Facsimile Recording Methods

The reassembly of the facsimile transmission has traditionally been done by a modulated light bulb shining onto a piece of photographic paper, requiring a darkroom and wet-process developing before the image could be viewed. This lengthy and costly procedure is unacceptable for use in modern business environments, prompting manufacturers to develop several alternative methods of recording the received signal.

In percussive recording (51), ordinary paper is paired with a sheet of carbon paper, and a stylus strikes the papers wherever a dark spot is indicated. If multiple copies are desired, several pages of ordinary and carbon paper can be interleaved. Advantages of this method are that no mixing or storage of chemicals is needed, the documents do not deteriorate greatly with age, and the recording process and resulting documents are odorless. A disadvantage is that the received document cannot be viewed until the carbon paper is stripped from the document;

thus, it is hard to detect and interrupt a faculty transmission. Also, carbon paper deteriorates with age, so for best results fresh carbon paper must be used.

In electrolytic recording, a damp, chemically impregnated paper is drawn over a writing edge of stainless steel; a writing electrode scans the other side of the paper and causes local darkening by passing an electric current through the damp paper. An advantage of this method is that faulty transmissions may be quickly terminated. The paper, however, may have chemical odors; it deteriorates both on the shelf and after recording and it may damage documents placed adjacent to it in a file.

In the electrosensitive method of recording, (51) a white surface coating on the paper is locally destroyed by the passage of an electric current flowing from the scanning stylus. This exposes the black subsurface underneath, recording a black mark. The special paper used is expensive, is damaged by pressure, and may emit objectionable fumes during recording. An alternative involves using a film of aluminum for the surface layer; current from the scanning stylus causes melting of the aluminum, which then recedes because of surface tension revealing the black subsurface. This paper is cheap and is odorless in use, but its unconventional appearance may be objectionable in some cases.

In electrostatic recording, a surface charge corresponding to dark areas is deposited on a special paper having a dielectric coating which prevents dissipation of the surface charge. As the paper advances beyond the recording position, it undergoes a development process in which toner powder is first attracted to the paper by the deposited electrostatic charge. The paper is then passed over a

heating element which fuses the toner powder to the paper. The resulting image can be viewed a minute or so after it has been recorded. This method of recording does not work well in humid environments where moisture might allow the surface charge to be dissipated before the image can be processed.

### 5.1.3 Signal Modulation Methods

Before sending the facsimile signal from the transmitter's scanning head into the communications system (typically, voice grade telephone lines), it must be processed for optimum reception by the facsimile receiver. This is generally done in one of two ways.

The signal may be only amplified before insertion in the communications network, resulting in an amplitude modulated (AM) signal. If this is the case, before actual transmission begins, two pilot signals are sent to the receiver. (50) These pilot signals are DC levels, one with amplitude corresponding to the transmitter's white signal level, the other the transmitter's black signal level, and are required because unlike human speech, whose information depends mostly upon the shape of the signal and little on the speech signal's amplitude (i.e. if the amplitude of the signal is increased, it gets louder, but the meaning stays the same), the facsimile signal's information is contained both in its shape and its amplitude. The shape of the facsimile signal tells where the original document changed shades, while the instantaneous amplitude of the amplitude modulated signal indicates the shading of the point being reproduced.

The two pilot signals are used to indicate to the facsimile receiver the levels which represent pure black and pure white, and are needed because a communication channel's attenuation generally is not

Table 13. Typical Facsimile Transceiver Specifications and Prices\*

Manufacturer	Model No.	Max. Page Size		Min. Scan Time Per Page, s	Transmission Mode			Max. Resolution		Scan Tech.
		Input, in X in	Output, in X in		Digital	Analog		Horiz. pel/in	Vert. lines/in	
					kbits/s	Bandwidth, kHz	Modulation			
Aiden	11	24 X cont.	11 X cont.	408	—	1.2	VSBAM	—	166	
	18	18 X 24	18 X cont.	132	—	—	—	—	166	
	600	6 X cont.	6 X cont.	—	—	—	—	—	96	
Dacorn	301	24 X 24	24 X 11	152	150	—	—	2000	1200	PE
	410	9.5 X 14	9.5 X 14	32	4.8	—	—	200	200	PE
	411	8.5 X 14	8.5 X 14	30	3.2	—	—	200	200	PE
	412	8.5 X 14	8.5 X 14	32	4.8	—	—	200	200	PE
	441	8.5 X 14	8.5 X 11	32	4.8	—	—	200	200	PE
Datalog	Message Fax	8.5 X 11	8.5 X 11	240	—	—	VSBAM	—	91	PE
	Digifax	8.5 X 11	8.5 X 11	240	9.6	—	—	—	91	PE
	VX T, R	8.5 X 14	8.5 X cont.	240	—	—	AM	—	91	
	501	22 X 15.4	12 X 15.4	240	—	—	AM	—	600	
	DDR	14 X 17	14 X 17	120	10.8	—	—	—	—	
EAI	FAX 115	9.5 X 14	—	—	0.8	—	—	—	180	FS
	FAX 130	9.5 X 14	—	—	4.8	—	—	—	180	FS
	FAX 150	9.5 X 14	—	—	2.4	—	—	—	132	FS
Faxon	311	8.3 X 10.8	8.5 X 11	32	—	—	FM	—	100	PE
Graphic Sciences	Flex Broadcaster	9 X 14	9 X 14	140	—	1.4	VSBAM	—	93	PE
	Flex	9 X 14	9 X 14	340	—	1.4	VSBAM	—	93	PE
	Flex VI	9 X 14	9 X 11	200	—	1.4	VSBAM	—	93	PE
	Flex VII	9 X 14	9 X 14	240	—	1.4	VSBAM	—	93	PE
	Flex X	9 X 14	9 X 11	240	—	1.4	VSBAM	—	93	PE
	Flex 100	9 X 14	9 X 14	100	—	1.4	VSBAM	—	93	PE
	Flex 130	9 X 14	9 X 11	140	—	1.4	VSBAM	—	93	PE
	Flex 131	9 X 14	9 X 14	140	—	1.4	VSBAM	—	13	PE
	Flex 142	9 X 14	9 X 14	140	—	1.4	VSBAM	—	93	PE
	Flex 181	9 X 14	9 X 11	140	—	1.4	VSBAM	—	93	PE
	Flex 180	9 X 14	9 X 11	140	—	1.4	VSBAM; FM	—	93	PE
	Flex 3000	8.5 X 11	8.5 X cont.	140	—	1.4	VSBAM	—	93	PE
Flex 3600	8.5 X 14	8.5 X cont.	140	—	1.4	VSBAM; FM	—	93	PE	
Flex 4100	8.5 X cont.	8.5 X cont.	140	—	1.4	VSBAM; FM	—	64	PE	
IV	140	9.5 X 14	9.5 X cont.	140	—	—	FM	95	96	
	200-300	8.5 X 11	8.5 X cont.	140	—	—	FM	95	96	
	400-500	8.5 X 11.8	8.5 X 11	140	—	—	FM	95	96	
Muirhead	120	—	9.8 X cont.	240	—	0.8	FM	—	90	
	140	—	9.8 X cont.	240	—	0.8	FM	—	90	
	200	—	9.8 X cont.	240	—	—	VSBAM	—	90	
	500	—	9.8 X cont.	240	—	—	—	—	90	
	K-351-D/F (Tr)	8 X 10	8 X 10	800	—	1.3	VSBAM	—	200	
	K-300-D/F (Rec)	8 X 8	8 X 8	200	—	1.3	VSBAM	—	200	
Mercury IV	—	—	—	—	—	0.3	FM	—	90	
Rapifax	100	8.5 X 14	8.5 X 14	36	2.4/4.8	—	—	200	200	PE
Stewart Warner	Datafax 150	8.5 X 11	8.5 X 11	140	—	1.0	FM	—	137	
	Datafax 180	8.5 X 11	8.5 X 11	240	—	1.0	FM	—	90	
	Datafax 240	8.5 X 11	8.5 X 11	240	—	1.0	FM	—	90	
	Datafax 350	8.5 X 11	8.5 X 11	140	—	1.0	FM	—	90	
	ST-2430A(B)	8.5 X 11	8.5 X 11	140	—	—	AM	—	90	
	ST-2430SA(B)	8.5 X 11	8.5 X 11	140	—	—	AM	—	90	
Telegraph	1000	8.5 X cont.	9 X cont.	140	—	2.0	VSBAM	—	100	PE
	11AD	8.5 X cont.	8.5 X cont.	140	—	2.0	AM	—	100	PE
	120	8.5 X cont.	8.5 X cont.	120	—	—	—	—	100	PE
	150	8.5 X cont.	8.5 X cont.	120	—	9.1	AM	—	100	PE
Victor Graphic Systems	1003	8.5 X 11	8.5 X cont.	100	—	—	FM	—	100	
	1100	8.5 X 11	8.5 X cont.	100	—	—	FM	—	100	
	1200	8.5 X 11	8.5 X cont.	100	—	—	FM	—	100	
	2001	8.5 X 11	8.5 X cont.	100	—	—	FM	—	100	
Xerox	Telecopier 400	8.5 X 11	8.5 X 11	240	—	2.5	FM	95	90	PE
	Telecopier 400-I	8.5 X 11	8.5 X 11	240	—	2.5	FM	95	90	PE
	Telecopier 410	8.5 X 11	8.5 X cont.	240	—	2.5	FM	95	90	PE
	Telecopier 410	8.5 X 11	8.5 X 11	240	—	2.5	FM	95	90	PE

ABBREVIATIONS USED: AM, Amplitude Modulation; FM, Frequency Modulation; VSBAM, Vestigial-sideband Amplitude Modulation; PE, Photoelectric scanning; FS, Flying Spot (Cathode-ray Tube) Scanning.

\*Reference: S. Kaplan, "Fax, specs and projections," IEEE Spectrum, 9/74, p. 77-81.



Table 13. Typical Facsimile Transceiver Specifications and Prices (continued)

BEST COPY AVAILABLE

(1974)

Manufacturer	Record. Tech.	Sync.	Data Comp.	Error Cor. rect.	Automatic Trans. Rec.	Biggest Dimension, in	Weight, lbs	Purchase Price/ Monthly Rental, dollars	Options
Alden	EI	—	—	—	✓	50 (h)	613		Auto. feeder
	EI	—	—	—	✓	55 (h)	809		Auto. feeder
	EI	—	—	—	✓	71 (d)	125		
Dacom	Ph	—	✓	✓	—	51.5 (h)	375	13 000/510	Auto. feeder
	Es	—	✓	✓	✓	39 (h)	375	14 130/520	Auto. feeder
	Es	—	✓	✓	✓	39 (h)	375	14 320/545	Auto. feeder
	Es	—	✓	✓	✓	39 (h)	375	12 700/470	Auto. feeder
Catalog	EI	PG	—	—	—	21.3 (w)	78		
	EI	PG	—	—	—	—	—		
	Ph	—	—	—	—	47.5 (h) 47.5 (h)	—		
EAI	Es	—	✓	—	—	43 (h)	300	9800/300	Auto. feeder
	Es	—	✓	—	—	43 (h)	300	9800/300	Auto. feeder
	Es	—	✓	—	—	43 (h)	300	11 300/300	(Auto. feeder) (Auto. answer)
Faxon	Es	—	✓	✓	✓	40 (w)	260		
Graphic Sciences	Sp	CL	—	—	—	22 (w)	47	9900/190	
	Sp	CL	—	—	—	22 (w)	47	1700/57.5	
	Sp	CL	—	—	—	22 (w)	47	1200/57.5	
	Sp	CL	—	—	—	22 (w)	47	1200/57.5	
	Sp	CL	—	—	—	22 (w)	47	1200/57.5	
	Sp	CL	—	—	—	22 (w)	47	4000/85	
	Sp	CL	—	—	—	22 (w)	47	4000/85	
	Sp	CL	—	—	—	22 (w)	47	4000/85	
	Sp	CL	—	—	—	22 (w)	47	4000/85	
	Sp	CL	—	—	—	22 (w)	47	4700/95	
	Sp	CL	—	—	—	22 (w)	47	4600/95	
	Sp	CL	—	—	—	22 (w)	47	6000/100	
IM	Es	CL	—	—	—	24 (w)	57	3195/90	Auto. feeder
	Es	CL	—	—	—	24 (w)	59	2995/85	
	Es	CL	—	—	—	18.4 (w)	18	1645/57.5	
Murhead	Es	PG	—	—	—	15 (w)	57		
	Es	PG	—	—	—	15 (w)	57		
	Es	PG	—	—	—	16 (w)	87		
	Es	PG	—	—	—	16 (w)	87		
	Ph	CL	—	—	—	23 (w)	75		
	Es	CL	—	—	—	50 (h)	375		
Papifax	Es	—	✓	—	✓	47 (h)	375		
Stewart Warner	EI	CL	—	—	✓	21 (d)	45		Auto. feeder
	EI	CL	—	—	✓	21 (d)	45		Auto. feeder
	EI	CL	—	—	✓	21 (d)	45		Auto. feeder
	EI	CL	—	—	✓	21 (d)	45		Auto. feeder
	EI	PG/CL	—	—	✓	19.5 (d)	160		Auto. feeder
EI	PG/CL	—	—	✓	19.5 (d)	163		Auto. feeder	
Teleautograph	EI	CL	—	—	—	19 (d)	135	6000/	
	EI	CL	—	—	—	19 (d)	136	6000/	
	EI	CL	—	—	—	19 (d)	135	6000/	
	EI	CL	—	—	—	19 (d)	136	6000/	
Victor Graphic Systems	Es	CL	✓	—	✓	18.5 (d)	123	5000/270	Auto. feeder
	Es	CL	✓	—	✓	18.5 (d)	123	5000/260	Auto. feeder
	Es	CL	✓	—	✓	18.5 (d)	123	5700/245	Auto. feeder
	Es	CL	✓	—	✓	18.5 (d)	123	5900/320	Auto. feeder
Xerox	Sp	CL	—	—	—	18.4 (w)	38	1540/65	
	Sp	CL	—	—	—	40 (d)	69	1540/60	
	Me	CL	—	—	—	17.8 (w)	35	1825/62.5	UA
	Sp	CL	—	—	✓	30 (d)	65	4580/100	

ABBREVIATIONS USED: EI, Electrolytic; PL, Photographic; Es, Electrostatic; Sp, Sparking (Electrosensitive); Me, Mechanical Impact (Percussive); PG, synchronization by the power-grid waveform; CL, synchronization by internal frequency standard; UA, unattended answering.



constant with time, causing the receiver levels corresponding to black and white to differ between transmissions. This is especially true for AM transmissions over switched communications networks, such as the telephone network, where a different transmission circuit, with resulting different path losses, will be likely to be used for each transmission. Thus, for AM signals, failure to recalibrate the facsimile receiver before each transmission could result in excessive loss of contrast in the received image. Recalibrating before transmission avoids this problem. However, recalibration cannot compensate for changes in transmission path loss during the transmission of a facsimile signal, which can occur, for example, because of the switching of other lines in the telephone system external to the particular telephone line being used.

To avoid these problems, most facsimile systems employ frequency modulated (FM) signals: for use with 3 kHz bandwidth voice-grade telephone lines, for example, a 2.1 kHz tone will correspond to black, while 1.3 or 1.5 kHz will correspond to white. Similarly, shades of grey will be represented by tones whose frequencies lie between 2.1 and 1.5 kHz. As these frequency modulated signals are little affected by changing path losses, the calibration problems associated with amplitude-modulated signals are avoided.

A listing of available facsimile transceivers, along with their specifications and prices, is given in Table 13.

### 5.2 SLOW SCAN TELEVISION (SSTV) (52)

In applications in which graphics are to be transmitted over a communications network but no hard (i.e. paper or microform) copy is required, SSTV may also be used. Its transmission techniques are

similar to facsimile's in that a still object is slowly scanned by a television camera, resulting in a signal which may be transmitted over a low-bandwidth communications system. Display of the received signal can be accomplished by any display with inherent memory. Two examples of suitable displays are standard cathode ray tubes used in conjunction with video-refresh memories and the plasma display panel used in the PLATO IV educational communications system.

Were a standard CRT to be used with a video refresh memory, the SSTV signal would first be recorded by the video refresh memory, and then played back repeatedly to the CRT as is done in the TICCIT system. The main difference is that while in TICCIT the frame is transmitted as a high-bandwidth signal lasting 1/60 of a second, in SSTV the frame is transmitted as a low bandwidth signal which may take minutes to complete the frame, a bandwidth vs. time tradeoff. (See Appendix A.1).

In addition to the digital refresh memory used in the TICCIT CAI system, which costs \$560 per unit and has no grey-scale capabilities, (30) (31) several other forms of video refresh memories, notably silicon storage tubes and magnetic discs, might find application in SSTV terminals. (53) In the silicon storage tube, a high intensity, amplitude-modulated electron beam assembles the TV picture as a pattern of charges by scanning a non-conducting "target." Once the picture has been assembled, a low-intensity electron beam can "read" the picture by repeatedly scanning the target. In doing this, the pattern of charges on the target interferes with the electron beam so that the current from the electron beam arriving at a conducting plate behind the target is a function of the charge pattern on the target. Disadvantages of

the silicon storage tube are high cost,\* relatively slow erase time (typically five TV frames) (54), and inability to refresh color displays. (30)

Magnetic disc recorders could also be used in SSTV terminals. To be applicable, the units would have to be able to record the SSTV signal at its several second per frame transmission rate, and then play the complete frame back repeatedly at 1/50th second intervals for display on a standard CRT. While no such two-speed unit presently is available, Hitachi offers a magnetic disc recorder for \$200 per unit\*\* which records a standard television frame as a 5-MHz FM signal which may then be repeatedly played back in frame-grabber applications. (55)

The plasma panel display, with its inherent memory properties, could be used in an SSTV terminal in place of a CRT and video-refresh memory. To use the plasma panel, the SSTV signal would be sampled, and each sample would be used to control a point on the panel, turning it on or off, depending upon whether light or dark shading was indicated. The plasma panel could only display two-tone graphics†; however, it is more rugged than cathode ray tubes and could be selectively erased.

In any case, the required resolution of the display (and storage capacity of the display's memory, where applicable) will be determined by the main use to which the SSTV terminal will be put. Experience with MIT's Project Intrex (56) has indicated that for displaying pages

---

\*\$600 per unit in 1973. (59)

\*\*in small quantities.

†Experiments conducted have shown that plasma panels can display at least three levels; (55) only two-level panels, however, are currently in use.

from technical journals for short-term viewing, 400- to 500-line pairs per page (800 to 1000 lines per frame) is the lower limit on acceptable display resolution while for reading detailed information such as sub- and super-scripts, mathematical formulas, footnotes, etc., limiting resolutions of at least 1000-line pairs per page (2000 lines per frame) are required.\*

Thus, an interactive system used primarily as an "electronic card catalog" having the capability of allowing users to briefly read selected documents to determine their content before ordering hard copies would require displays having resolutions of only 500-line pairs per page.

Because the display's resolution along both horizontal and vertical axes would be twice that of a standard broadcast-quality display's resolution, the display's video refresh memory (VRM), if used, would be required to have four times the storage capacity (or in the case of an analog memory such as a magnetic disc, four times the bandwidth-time recording capacity) of a VRM used to regenerate broadcast-quality frames. Similarly, if the main use of the system was actual dissemination of library materials by SSTV, special displays having four times the resolution and (where applicable) VRM's having sixteen times the storage capacity of similar units used to generate broadcast-quality displays would be required. This would be significant when considering the design of a system which would deliver both CAI and document-quality SSTV to remote terminals, as visual displays adequate for CAI would be grossly inadequate for SSTV display of library materials. High resolution CRT's are available, (65) but, along with their associated hardware,

---

\*These correspond respectively to roughly two and four times the resolution of a standard broadcast-quality TV frame.

are more complex and expensive than standard broadcast-quality CRT's. Prototype plasma panels with an element density of 60 lines per inch have been developed (57); thus, a 500-line pairs per page display would require a panel 16.67 inches by 22.22 inches\*, while a 1000-line pairs per page display would require a 33.33 inches by 44.44 inches plasma panel.\*

### 5.3 APPLICATIONS OF FACSIMILE AND TELEVISION IN INTERACTIVE LIBRARY SYSTEMS

As we discussed in the introduction to this section, present day libraries have had to contend with rising prices and the increasing amount of basic materials published each year which must be obtained to maintain library standards. One possible solution to the problem of providing better services might be to centralize library facilities, with distribution of materials via a broadband educational communications network.

By storing library materials in microform, storage space requirements could be greatly decreased while facilitating machine handling of materials. Library users would have access to library materials through the interactive terminals of the system, possibly with the assistance of a computerized card catalog through which references could be obtained by the user's answering of a series of questions allowing the computer to select the materials most likely to contain specific information needed.

Distribution of requested materials might be done by SSTV, with local electronic storage being provided at the interactive terminal in the form of audio cassette recorders which were remotely controllable

---

\*3:4 aspect ratio.

from the library materials distribution center, allowing overnight distribution and storage of large volumes of materials. For one example, the amount of storage available per cassette could be computed as follows: The RCA Videovoice SSTV terminal set is capable of transmitting a broadcast-quality SSTV frame (34) over voice-grade telephone lines of 3 kHz nominal bandwidth in 55 seconds.\* Assuming the interactive terminals were equipped with cassette tape recorders having a bandwidth of 15 kHz, a broadcast-quality SSTV frame could be transmitted as a 15-kHz SSTV signal in 11 seconds. Thus, an audio cassette having 562.5 feet of audio tape (60 minutes of tape at 1 7/8 inches per second) could record 1300 frames of broadcast quality per cassette.\*\*

Recalling that the lower limit on acceptable resolution for displaying a page of textual material is roughly twice that of a broadcast quality frame and requires four times the bandwidth-time storage capacity, it would require 44 seconds of a 15 kHz SSTV signal to transmit a page of marginal resolution; 325 such pages could be stored on an audio cassette. Similarly, 176 seconds of 15 kHz SSTV signal would be required to transmit a high-resolution (having four times the resolution of broadcast-quality frames) frame of textural materials and only 80 such frames could be stored per cassette.\*

---

\*This is approximately equivalent to a 4.5 MHz frame in 1/30 sec.  
(See Appendix A.1).

$$** \frac{1 \text{ frame}}{11 \text{ seconds}} * \frac{60 \text{ seconds}}{\text{minute}} * \frac{60 \text{ minutes}}{\text{hour}} * \frac{1 \text{ hour}}{\text{track}} * \frac{4 \text{ tracks}}{\text{cassette}} = \frac{1309 \text{ frames}}{\text{cassette}}$$

$$* \frac{1300 \text{ broadcasting quality frames}}{\text{cassette}} * \frac{1 \text{ high resolution page}}{16 \text{ broadcast quality frames}} = \frac{81.25 \text{ high res. pages}}{\text{cassette}}$$

Because most interactive users would find the delay between frames excessively annoying,\* the system must be modified to permit faster retrieval of requested frames. Neglecting for a moment the time required to retrieve subsequent frames for transmission, it can be shown\*\* that to transmit a high-resolution page in one second requires a channel bandwidth (and terminal recorder bandwidth, where applicable) of 2.64 MHz, indicating that for on-line materials retrieval, slow-scan TV is not an acceptable transmission technique.

SSTV could be used, however, in conjunction with the SCA channels of FM broadcast stations to distribute textual materials having mass appeal (i.e. non-interactive) over large sparsely populated regions where other alternative information systems were deemed impractical. A similar system utilizing the horizontal retrace intervals in standard NTSC television signals to transmit newspapers to home facsimile receivers has been designed by RCA (50); while there are no engineering obstacles to its implementation, a market for the service has never been established. Because of rising paper prices, a similar system using SSTV instead of facsimile to transmit textual materials might in the future prove to be marketable.

---

\*Experience with Project Intrex, a ten year research project at M.I.T. concerning possible applications of technology in future library systems (58), has shown that delays of up to 10 seconds are tolerable in retrieving the first page of a requested document, but subsequent pages should be retrieved rapidly (in less than 1 sec) to facilitate browsing through the document. (56)

\*\*As noted earlier, 176 seconds of 15 kHz bandwidth SSTV signal are required to transmit a high-resolution frame. If the frame is to be transmitted in one second, the bandwidth of the signal, 15 kHz, must be multiplied 176 times so that the bandwidth-time product remains constant (see Appendix A.1). Thus, to transmit a high resolution frame in one second requires a signal whose bandwidth is  $176 \times 15 \text{ kHz} = 2.64 \text{ MHz}$ .

In the design of any interactive library system, the heart of the system would be the microform storage and retrieval hardware, which by computer control could locate and retrieve for transmission microimages requested from remote user terminals. One such system, the Mosler 410 Information System manufactured by the Mosler Safe Company (59), is able to retrieve and display on independent remote television viewing terminals any requested unit document (i.e., tabulating card, aperture card, or microfiche) from a file module within ten seconds. File modules can be multiplexed together to create system storage capacities in excess of one million unit documents. The price of the basic retrieval system started at \$30,000 (100,000 unit documents capacity), while its remote television viewing systems were priced \$70,000 and up. Because of limited market for the system, it is no longer manufactured. (60)

A similar system, the 626 Information Storage and Retrieval System distributed by Varian ADCO, (59) does not require a computer for operation and is designed for inexpensive modular expansion from as few as 10,000 documents to millions of documents. The system's optical search head can scan a file of 1000 microfilm carriers in one second, and the system can display any document from a file on the system's single remote display terminal within six seconds.\* The microforms are viewed by a video camera which produces an image with 1225 line resolution. (59) Controls on the terminal allow the operator to scan the microform along X and Y axes, allowing frame selection.

---

\*Presumably, the operator must indicate which file is to be searched, as the unit does not have computer indexing and to scan all of the files in a large system would take an excessive amount of time.



A third system, the CARD/COM 80 Model 201, is a storage/retrieval microfiche reader with a capacity of 750 microfiche; any frame upon one of the stored fiche can be accessed and optically displayed upon the reader's screen within four seconds. Because each frame on the fiche is machine-indexed by a number-letter combination, subsequent frames on retrieved fiche are accessible within one second.\* The basic unit's price is \$4750, while a unit with computer interface permitting the CARD reader to be directly controlled by a computer is available with prices starting at \$7800. (59)

It should be noted that none of these units (or for that matter, any presently available microform storage/retrieval units) combine all the features needed for use in an interactive library system. For an interactive library system to be as convenient to users as open library stacks, its storage/retrieval system would have to combine some features of all the units mentioned, in addition to other features. First, it would require a large enough capacity to store a significant number of microforms; were the document collection of the interactive system too small because of limited storage capacity, the system's support base would suffer, which would probably cause the system never to be built. Similarly, although each retrieval device (using single frame transmission techniques and frame grabbers at each user terminal) could simultaneously serve several user terminals, the document file need have multiple independent retrieval units. Otherwise, excessively long queues for the single retrieval unit might develop. A further requirement would be that individual microforms should be accessible

---

\*The CARD reader, modified for use with remote video displays, was used in Project Intrex, in which the one second time limit was determined. (6)

to several users simultaneously. While this is not absolutely necessary, for viewing standard works in selected fields, current periodicals, etc., it would greatly increase the system user's convenience.

To facilitate browsing, the system should be able to perform initial document retrieval within ten seconds, with display of subsequently requested frames within one second. This would probably require the retrieval system to have two-level storage; that is, a main storage facility in which microforms not in use would be kept, and a buffer storage from which microforms in use could quickly be accessed. To further facilitate speedy retrieval of subsequent frames, the microforms used would need to have standardized format to allow machine indexing of individual frames.

Finally, the storage/retrieval unit's image scanners and signal processing equipment must be considered. The image scanners must of course be capable of reproducing frames with a resolution acceptable to the user. In addition, they should be dependable to reduce the amount of maintenance required. In Project Intrex, microfiche scanning was accomplished through the use of lenses and a photomultiplier tube. (61) Today, this could probably be done more reliably and inexpensively by charge-coupled devices.

Recently, integrated circuit arrays of charge-coupled devices (CCD's) have been made commercially available by the Reticon Corporation and Fairchild Semiconductor. (62, 63, 64) Consisting of arrays of photo-sensitive semiconductor devices, each device accumulates an electric charge proportional to the amount of light falling on it. When the devices are serially scanned, the output is a signal waveform corresponding to light and dark areas as perceived by the CCD array.

Advantages of CCD arrays over vacuum-tube scanners include ruggedness, high dynamic range, and low voltage and power requirements.

Because the microform storage/retrieval hardware will be shared among many remote users, some form of coding specifying the destination of the retrieved frame's signal will be required. This can probably be provided in the same manner as is done in the TICCIT-CAI system. In fact, the network and terminals used by the interactive library system could also be used for CAI with few restrictions.\* In that case, the system coding for interactive library use and CAI would be designed to be compatible.

Finally, depending on the availability of system terminals to individual users, provisions for obtaining hard (full-sized and/or microform) copies of library materials must be included among interactive library services. In areas without extensive library services, this could be implemented simply with telephone ordering and mail distribution of copies from the central storage facility; otherwise, this might be accomplished through the interactive system by facsimile transmission to remote facsimile receivers, with provisions for ordering copies from remote user terminals. In the latter case, because facsimile information must in general be transmitted more slowly than television information to allow recording on physical media, special allocations within the network for the slower facsimile transmission would be made.

---

\*Specifically, the network described here does not include provisions for sound programming or color displays. Audio-compression techniques might be used to transmit audio programming for CAI during part of the interval normally used to transmit the higher resolution frame required for textual displays. Unfortunately, because color CRT's are unable to attain resolutions greater than (typically) 600 lines regardless of screen size, (65) the CRT's used for textual presentation must be black-and-white.

An alternative would be to equip the remote facsimile receivers with memory systems capable of recording the fax signals transmitted at television rates for playback at rates suitable for recording the facsimile signal on physical media. In this system, the original signal waveform would be provided by an optical scanner of the microform storage/retrieval unit; the signal, after processing, would be recorded by a facsimile receiver such as the Alden 9257 Alspeed Recorder (59), priced at \$9500 and capable of recording fax signals with bandwidths from 3 to 48 kHz. Microform facsimile copies might be made using computer output microfilm (COM) techniques.

A final caution should be mentioned concerning widespread use of facsimile with respect to existing copyright laws. Because the interactive library system as described would be equipped to provide users with low cost copies of library materials, it could be thought of as a "mini-publishing house." Having the capability of providing users with hard copies of complete volumes on microform at prices much less than the purchase price of the original work, users might find it more attractive to order copies of full texts from the system than to purchase the desired texts. In these cases, the system would be operating in violation of copyright laws, which allow the copying of copyrighted materials only for "scholarly research."\* Thus, before the system could be legally implemented, present copyright laws would have to be modified, or a schedule of royalty payments would have to be arranged.

---

\*This was practical before the availability of microform copying equipment, as to copy a full text at five to ten cents per page would, while yielding an inferior product, be generally more expensive than buying the original text.

Terminals for use with the interactive library system would likely include a high-resolution CRT display, a frame-grabber for video refresh, and a keyboard through which users could address the system. As such, the proposed terminals are very similar to the terminals used in the TICCIT CAI system, suggesting that interactive library terminals might also be used with CAI.

While black and white CRT's are available with 4500-line resolution in any tube size, (65) there are no video refresh memories available having sufficient capacity to refresh a 2000-line display. These might be realized, however, by using multiple digital refresh memories (such are used in the TICCIT system) and addressing them serially. An alternate mentioned earlier, would be to use a sufficiently dense plasma panel display; if available, it would be more rugged and would not require a refresh memory.

The network required for an interactive library system would be determined by the number of remote terminals and the size of the area to be served by the system. As mentioned previously, a channel bandwidth of at least 2.64 MHz would be required to transmit a high resolution frame within one second. More likely, the channel bandwidth chosen would be 4.5 MHz to allow the use of commercially available broadcast television processing equipment. The network itself could comprise a dedicated cable system or shared channels on a community CATV system. Long distance transmission between libraries might be provided by dedicated microwave links or arrangements with common carriers.

#### 5.4 INTERACTIVE INDEXING CONSIDERATIONS

The interactive library services already discussed have the potential to make library usage more convenient while partially solving the present materials-handling problems which libraries face. In a sense, however, these hardware-oriented approaches are not innovative, in that while they would provide more convenient methods of accessing library materials, the means by which users search the library collection would only be mechanized, not improved. It is to this aspect of library services, interactive indexing, that this section is devoted.

The rapidly growing volume of textual materials, while posing a handling problem for libraries wishing to keep their collections current, likewise poses a problem for library users wishing to keep abreast of the current developments in their fields. This is especially true for professionals (e.g., doctors, lawyers, engineers), for whom current development might greatly affect accepted practices. Similar problems are faced by researchers in the natural and social sciences, where lack of awareness of research being done elsewhere can lead to duplications of effort.

These problems could be minimized in an interactive library system by the addition of an interactive index system having the ability to assess the content of its document base. This would enable the interactive system to prescreen documents for relevancy, sparing researchers using the library much of the tedium associated with document searches. Also, depending on the comprehensiveness of the indexing system, more thorough searches of the library document base might be made by machine, especially in subjects largely unfamiliar to the researcher.

One example of an interactive indexing system is the New York Times Information Bank. (66) Designed originally to allow easy access to past news articles for reporters and newspaper editors, the Information Bank is an on-line, interactive system that provides access to all news and editorial matter published in the New York Times as well as selected articles from some sixty other publications. The Information Bank's computer facility, consisting principally of a high-speed processor [IBM 370/145] and high speed disc storage devices located in New York City, can be linked to CRT terminals nationwide via ordinary telephone lines, either leased or dial-up.

The material in the interactive data base consists of abstracts which vary in length according to the factual contents of individual articles; in many cases, it is thought that the abstracts will be sufficiently informative to answer users' questions without requiring users to consult the source articles. The abstracts are indexed in depth, with index terms consisting of all significant subjects, geographic terms, and company or organization names occurring in the articles. There is no limit to the number of index terms which may be assigned to any one article; index terms are entered into the computer data base along with complete bibliographical information on the article.

To obtain information from the data base, the user signs on at his terminal and then enters several index terms describing the subject in which he is interested. These index terms are then individually checked by the system computer against a machine-stored Thesaurus, a printed copy of which is available to the user at each terminal. If the index terms do not match terms within the Thesaurus precisely, a

brief dialogue takes place between the user and computer, during which the user can select the appropriate index terms from lists displayed on his terminal screen.

The messages that form the computer's part of this dialogue are in terse, non-technical English. After the user selects his index search terms, he may, if he wishes, restrict the search according to bibliographic criterion such as date, source, etc. The user is then asked to form the index terms into a "logical search request"; that is, using the Boolean operators AND, NOT, and OR, the user requests the computer to search and compare several files concurrently and to retrieve only those articles contained in the subset specified by the logical search request. An example of a typical inquiry might be:

"McGovern OR Eagleton AND Israel OR Suez Canal."

This logical search request would cause the Information Bank computer to select material on Senators McGovern and/or Eagleton in connection with Israel and/or the Suez Canal.

As soon as the logical search statement has been entered, the computer searches the designated files. Having selected the desired material, the computer then gives the user the choice of having the material sorted chronologically in normal or reverse order. The user is then shown the first abstract selected; he may look at the abstracts in the order they have been sorted, skip through the listing of abstracts or have any abstract printed on the hard copy printer supplied with most user terminals. Complete bibliographical data is supplied in case



the user finds it necessary to refer to the source article.\* Should the user find that his search statement was too general or too limited, he can alter his search specifications and initiate another computer search.

The development of the Times Information Bank cost in excess of three million dollars. Presently, a full-scale marketing effort to libraries, and information centers is underway. Subscriptions are offered at prices ranging from \$675 per month to \$1350 per month, exclusive of terminal, communications line cost, and microfiche document base; the subscription price is dependent upon the amount of use and time of day for use the subscriber requires. The New York Times on microfiche costs \$900 per year. Terminal costs are about \$350 per month, while the communications line cost will depend on type of line and on distance from New York City. An additional plan for universities and public libraries entailing installation of a terminal at minimal charges and then charging for Information Bank services on a per use basis is also under consideration.\*\*

It is evident from the cost data on the Times Information Bank that similar systems suitable for use with the large document collection of an interactive library system would require a large support base to make the interactive index system economically feasible. To obtain these

---

\*It should be noted that the source articles are not available for viewing over the Information Bank terminal. To view source articles, the user must consult either the institution's newspaper collection, or the New York Times on microfilm through convention microfilm viewers.

\*\*The Brooklyn Public Library is currently offering the public access to the Times Information Bank on a trial basis. (67)

large support bases, and to increase index utilization, interactive index systems might be designed for use by all of the interactive libraries within large geographic regions; such a system might be accessed over the same network used for interlibrary loan transmissions. In fact, since the interactive index would presumably contain a listing of all the documents contained in libraries within the region, and since the location of the documents could easily be added to the bibliographic data in each document abstract, the interactive index system might be used to coordinate interlibrary transmission of documents over a dedicated educational network.

## 6. SUMMARY AND CONCLUSIONS

### 6.1 PURPOSE OF THE REPORT; RELATION TO OTHER WORK

We intend this memorandum to serve as a useful systems design tool in an engineering and economic study of communications technology applied to education. However, it also includes much descriptive material useful to the nontechnologist interested in educational networking. For the engineering study, the memorandum provides an important part of both the background information and the analysis necessary to conceptualize and evaluate alternative communications networking schemes for the delivery of educational services.

The background information we provide gives the designer of educational networks a broad engineering overview of the range of educational services deliverable by communications technology. We review the capabilities, costs, and communications requirements of these services. As additional background, we give a brief description of existing educational networks, such as those serving broadcast educational radio and TV.

The analyses we undertake are preparation for the evaluation of the performance and costs of various network design alternatives. We evaluate, and where possible, compare, existing implementations of communications networks which deliver educational services. An example of this type of analysis is our comparison of VHF and UHF broadcasting for educational TV. We cite channel availability, coverage area, signal quality, and costs in making this comparison.

A second example of the analysis this memorandum undertakes is our attempt to predict how some new or experimental educational services will perform when implemented in an operating network. In one instance, we analyze the effect of an above-average load factor on the

responsiveness of a proposed network for the TICCIT system, an experimental, interactive television system for home and institutional use.

This paper's engineering work, oriented for one familiar with communications technology but not with its educational applications, will not suffice as the sole source of information in the formulation and analysis of alternative networking schemes. This effort is of wide scope: it must, to produce realistic results, consider markets for the services delivered, organizations for control and funding of networks, and many other issues. However, the information we present, when used in conjunction with other available results, should provide a relatively complete basis from which to work.

Some of the additional results needed are technical in nature. To formulate realistic designs, one needs a basic understanding of the potentially applicable communications technologies, but this information is available in numerous texts, journal articles, and design handbooks. Therefore, our work discusses these technologies only to describe the limitations the technology puts on the services it delivers. To cite one instance, the coverage area and signal quality of AM radio depend on propagation characteristics, bandwidth limitations and transmitter power. Our memorandum discusses these limitations in the specific context of describing how they effect the quality of educational radio.

In addition, a number of other issues, not specifically technical, will determine the success of the network configurations formulated. Two examples are, first, the identity and the needs of users of the network, and second, how and by whom the network could be controlled and supported. This memorandum does not consider these topics, but they

have been the subject of intensive research at the Center for Development Technology and elsewhere. The results of much of the Center's work in these areas are available in companion documents (68-75).

The rest of this summary section briefly reviews the work of the memorandum. This review is intended to highlight the conclusions we developed in the course of this work.

## 6.2 RESULTS OF THIS REPORT

We begin by describing and analyzing one communications technique presently delivering educational services, broadcast educational radio. Radio broadcast allows inexpensive distribution of non-interactive audio programming to large audiences. We review the history and present status of educational radio networks. We determine typical costs for station equipment and derive areas of coverage as a function of transmitter power and antenna height for both AM and FM radio. We also discuss the availability of channels for each, and using our cost and performance data, compare the amount and quality of programming each could provide. The comparison indicates that for most non-interactive audio educational programming, FM radio, with costs similar to AM, available dedicated educational channels, higher fidelity, and ability to distribute several channels of programming per radio channel, is superior to AM radio for most educational uses. However, in cases where large, sparsely populated areas are to be served, AM broadcasting might provide the only practical broadcast distribution method for educational radio.

We examine VHF and UHF educational television similarly. We determine typical operating and equipment costs, and we derive radii of coverage for various combinations of transmitter power and antenna

height. Our comparison of VHF and UHF channels indicates that, because of its higher possible coverage and the existence of superior VHF tuners in most existing privately owned television receivers, VHF television is technically preferable to UHF television for distributing educational programming. However, because a limited number of VHF channels are available, many educational television stations might be forced to use the UHF channels and suffer the associated penalties.

In an attempt to indicate some of the options possible when designing a CAI system or implementing other interactive educational services, we examine two experimental interactive networks with educational applications. These systems are Mitre Corporation's TICCIT systems and the University of Illinois at Champaign-Urbana's PLATO IV system. The TICCIT system uses a minicomputer to provide CAI services either full-time to 128 dedicated institutional terminals or part-time to up to 1000 home terminals, a number determined by cable capacity. We list the types and costs of the equipment needed in the proposed or implemented TICCIT systems. We also analyze the TICCIT system to predict exactly how much service it can provide to homes connected to the system by a cable television network. To do this prediction, we perform a queuing analysis of the proposed TICCIT system to be built in Stockton, California. The analysis indicates that, on the average, there is little chance of users having to wait before receiving TICCIT services. However, this result is quite sensitive to parameter variations. We note, for example, that there is a possibility that users might experience objectional waits before services become available during the high-load evening hours. One of our figures shows that an increase of only 5% over the average system

load factor could increase twofold or more the probability of having to wait for service.

We next examine the PLATO IV system, which uses a large general-purpose computer and innovative display technology to allow versatile CAI to be distributed long distances over low bandwidth lines. We examine system hardware costs and the amount of service the PLATO system provides. We find that the present developmental PLATO system can serve only 1000 terminals (rather than the 4000 terminals the system is designed to serve) because of the heavier than expected load that users are presently placing on the system. We also analyze the assumptions concerning the amount of system use that can be expected (which affects the cost of instruction per student contact hour) and the cost of producing sufficient courseware to attract enough system use to ensure that the cost of PLATO CAI remains reasonable. As a general conclusion, we find design assumptions made in these areas by PLATO's developers were optimistic.

We examine the Bell System's proposed Picturephone <sup>®</sup> service, a third interactive communications network and the only one with two-way, point-to-point video capability, for its applicability in carrying educational services. Because of its low resolution and high communications cost, Picturephone <sup>®</sup>, if implemented in its planned form, is unsuitable for use in many foreseeable educational communications applications.

We study the technologies which might be used to supply interactive library and document transmission services over future educational communications networks. We analyze facsimile and slow-scan television currently in use for document transmission, and we find that

these systems are likely to be too expensive and inconvenient to be widely used in future educational applications. However, facsimile might be used to supply document transmission to regional terminals, at which point users could pick up requested materials.

We discuss the resolution requirements of the displays which would be needed to provide interactive library services at user terminals, and determine the various display/refresh memory combinations which might be successfully used to meet the requirements. We describe the features of the selection mechanism needed in a remote microfilm-based library system, and we describe a promising and relatively new development, interactive indexing systems.

This information about, and analysis of, possible services which can be delivered by educational communications networks, will provide a basis for our future research. The work we plan will be a systems synthesis effort, in which we will attempt to design and evaluate a set of educational networks capable of delivering different levels of services to potential home and institutional users. Relatively unsophisticated delivery networks may develop. On the other hand, educational services might be carried to terminals over the unused capacity of CATV networks, or perhaps dedicated networks for education may develop; we will consider the range of possibilities. By designing a set of networks to provide different levels of educational services, we will attempt to find a level at which we can provide the most versatile educational service package possible given an estimate of the available user support.



APPENDIX A.1

TECHNICAL PROPERTIES OF INFORMATION

TRANSMISSION AND DISPLAY

To understand some of the constraints and tradeoffs involved in the design of educational networks, some of the technical properties of information transmission and display must be considered. These concepts allow the network designer to balance the rate of information transfer within the network against the quality with which the information is finally received; in doing so, the designer can ensure that a given network will provide educational services as efficiently as possible.

Two concepts central to any discussion of electrical communication, frequency and bandwidth, relate to the rate at which information is generated or may be carried by the network. Frequency is an indication of the rate at which a signal is varying; these variations are measured in Hertz (Hz), a unit equivalent to a signal variation of one cycle per second. Bandwidth, on the other hand, refers to the range of frequencies present in a signal or to the range of frequencies a communications channel can carry. As an example, human speech is made up of frequencies from 100 to 8000 Hz (.1 to 8 kHz). Thus, to reproduce faithfully the human voice, a telephone channel would need a bandwidth of 7.9 kHz, the difference between the high and low frequencies making up human speech. Most of the power in speech, however, is contained in frequencies below 3 kHz. Because of this, the telephone, with its 3 kHz bandwidth (0 Hz to 3 kHz), can reproduce speech that is intelligible although sounding different from the speaker's voice. A person's voice sounds different

over the telephone than it does normally because some of the information contained in the speech waveform (the high frequencies) is lost during transmission through the telephone system.

In most modulation\* techniques, each bit of information that a signal is to convey per second requires that the signal have a bandwidth of at least one Hertz (1); in some cases, in order to gain noise immunity or simplify the signal processing equipment needed, several Hertz per bit will be used. Because of this, the rate of which information can be transmitted over a channel is limited by the channel's bandwidth. Similarly, because the rate at which a signal conveys information determines the range of frequencies which the signal must occupy, it also determines the minimum bandwidth that the signal may have.

We have already discussed how using three - kHz bandwidth telephone channels results in speech which is intelligible but of low quality (i.e., low fidelity). A similar measure of quality for the visual displays used in educational networks is display resolution, which roughly corresponds to the amount of detail (information) reproducible in the display. Before discussing resolution, however, we must examine the methods used to transmit and receive visual images in educational networks.

Ordinary television programming consists of thirty still pictures (frames) per second; because of the persistence of human vision, it is possible to produce on the television screen the illusion of continuous motion by rapidly superimposing a series of stationary frames. Each

---

\*The process by which information is imposed onto a signal for transmission.

television frame, in turn, is composed of 525 parallel lines,\* each line being formed by an electron beam sweeping horizontally across a phosphor mask on the face of the television receiver's picture tube. The electron beam in the receiver's picture tube is moved in synchronization with the electron beam which scans the image viewed by the television camera's pickup device (i.e., camera tube). By varying the strength of the electron beam in the receiver according to information about image brightness received from the television camera tube, the receiver's electron beam sweeps a line having regions of different brightness across the phosphor mask of the receiver's picture tube, duplicating the line in the image viewed by the television camera. By displacing consecutive lines downward, the entire image viewed by the camera tube is reproduced.\*\*

Ideally, the areas scanned at any instant by the electron beams in the television camera and receiver picture tube would be points, allowing consecutive scan lines to be positioned as closely as desired without having any overlap between consecutive lines. In reality, however, the areas scanned at any instant by the electron beams are small circles; because of this, consecutive scan lines must be separated by a

---

\*Of the 525 lines, 485 are actually used in forming the television frame; the remaining 40 represent the time during which the electron beam "retraces" from the bottom to the top of the screen.

\*\*Rather than scan the 525 lines consecutively (i.e., 1, 2, 3, ..., 525), first the odd numbered lines (1, 3, 5, ..., 525) and then the even numbered lines (2, 4, 6, ... 524) are scanned. This is termed interlaced scanning, and each television frame is said to consist of two fields, one containing the even-number scan lines, the other the odd-number scan lines. To complete the scanning of each field requires 1/60 of a second. Interlaced scanning is used to further reduce the flickering of the television image perceived by the viewer. (2)

minimum distance to prevent overlap. Another consequence of the area excited by the electron beam being a small circle rather than a point is that in standard television, each scan line can be thought of\* as being composed of 640 areas, each of the area of the electron beam (3); each of these areas contains the average brightness in that region of the scan line, represents one piece of video information, and is termed a picture element (pel). The more pels per frame, the more accurate is the reproduction of the scene viewed by the camera.

One measure of the accuracy of display reproduction is the number of picture elements per unit length along the horizontal and vertical axes of the display\*\*; this is termed the display's resolution. Resolution measured in lines per inch (equivalent to pels per inch in most displays) is an indication of the detail the display is able to reproduce; in video displays, resolution is often measured in terms of the number of scan lines per frame. Resolution is also indicative of the

---

\*In displays comprised of discrete points, such as PLATO IV's plasma panel, or in television displays refreshed by digital refresh memories as are used in the TICIT interactive television system, each scan line is actually made up of a countable number of picture elements. In analog display systems such as standard television, while continuous (non-discrete) waveforms are used, the maximum number of distinct areas in a alternating light-dark "checkerboard" frame that the display can reproduce is equivalent to the number of pels in the display.

\*\*Resolution along the horizontal and vertical axes is usually equal; if not, the display's resolution is equal to the lesser of the two resolutions along the axes.

amount of video information contained in a display; the amount of video information is proportional to the square of the resolution.

We will now examine the three tradeoffs involved in communications network design. The first tradeoff is illustrated in the use of three-kHz telephone lines to carry eight-kHz bandwidth speech signals. If the message to be carried allows, the time rate of the message being held constant, the bandwidth of the transmitted signal may be decreased as long as the quality of the signal reproduction remains acceptable. You can trade bandwidth (which, as discussed earlier, is equivalent to the rate at which information is being generated) for picture quality. This tradeoff is also used in sending Picturephone <sup>®</sup> signals over 1-MHz bandwidth channels. Because a low resolution video display is acceptable to Picturephone users, the 4.5-MHz bandwidth channels needed to transmit broadcast-quality video are not required.

The second tradeoff possible in communication network design is illustrated by the use of slow-scan television to send single broadcast-quality video frames over 3-kHz bandwidth telephone lines. In this case, because the frame is to be of broadcast-quality, the amount of information in the SSTV frame is the same as the amount of information in a frame of standard broadcast television. Unlike the broadcast television signal, which has a bandwidth (information rate) of 4.5 MHz, however, the bandwidth (information rate) of the SSTV signal is limited to 3 kHz by the bandwidth of the telephone channel. To transmit a given amount of information over a lower bandwidth (information rate) channel requires that the transmission be longer. This is the key to the second tradeoff. Reproduction quality being held constant, if the

bandwidth (information rate) of a system is reduced, transmission time must be increased (and vice-versa).

The third network tradeoff possible is illustrated by the digital video refresh memories used in the TICCIT interactive television system. In this case, the signals generated by the VRM must be standard 4.5-MHz bandwidth broadcast television signals; otherwise, they will not be able to be received on standard television receivers. On the other hand, because the TICCIT interactive frames contain only a limited number of alphanumeric characters or line segments, displays of less than broadcast quality are acceptable. To save money on the VRM, therefore, the TICCIT system designers use a video refresh memory which records only one field per frame; this field is then transmitted twice per frame, resulting in a video display which has the full bandwidth but only half the resolution of a broadcast quality frame. In this case, (non-redundant) information is being transmitted only 50% of the time. This is the key to the third tradeoff. Signal bandwidth (information rate) being held constant, time can be traded for reproduction quality (and vice-versa).

The three tradeoffs discussed above allow educational network designers to balance the rate of information transfer, reproduction quality, and speed of response of the network so that practical services can be provided over the network as efficiently as possible. Each of the media systems discussed in the main body of the paper can be seen to include such a compromise.

APPENDIX A.1 REFERENCES

1. H. Busignies, "Communications Channels," Scientific American, September 1972, pp. 99-113.
2. V. K. Zworykin and G. A. Morton, Television, J. Wiley and Sons, Inc., New York, 1940, pp. 171-213.
3. E. Dickson and R. Bowers, The Videophone, A New Era In Telecommunications: A Preliminary Technology Assessment, NSF-RA-S-73-004, Cornell University, June 1973, pg. 13.

APPENDIX A.2

DETAILS OF THE DIGITALLY ADDRESSABLE RANDOM

ACCESS IMAGE SELECTOR AND RANDOM ACCESS

AUDIO SYSTEM USED IN PLATO IV (1)

A.2.1 Random Access Image Selector

The random access image selector used in PLATO IV student terminals can randomly access any of the 1/4 in. square images contained on a 16 x 16 matrix with a worst-case time of .2 seconds. This is accomplished by physically moving the matrix simultaneously along either of two Cartesian coordinate axes in order to position the desired image over a projection lens; this movement is done by a set of four pneumatic cylinders mounted in series along each coordinate axis.

The stroke length of each cylinder is weighted 8, 4, 2, 1, the length of the smallest being 1/4 inch. The valves controlling each cylinder are controlled by solenoids; when a solenoid is in its "on" position, the corresponding cylinder will be fully extended, while when the solenoid is in its "off" position, the corresponding cylinder will be fully retracted.

The weights of the four cylinders 8, 4, 2, 1, correspond to  $2^3$ ,  $2^2$ ,  $2^1$ ,  $2^0$ . Because of this, each coordinate in the film plane can be specified by four data bits, and each frame can be specified by eight bits. For example, if solenoid "off" corresponds to a zero bit, and solenoid "on" corresponds to a one bit, the eight bits used to specify the picture in the ninth row and fifth column would be 10010101. The first four bits, 1001, extend the row cylinders weighted  $2^3$  (=8) and  $2^0$  (=1) while retracting the cylinders weighted  $2^2$  (=4) and  $2^1$  (=2)



to select the ninth row, while the last four bits, 0101, would extend the column cylinders weighted  $2^2$  (=4) and  $2^0$  (=1) while retracting the cylinders weighted  $2^3$  and  $2^1$ . Thus the frame with coordinates (9,5) would be positioned for viewing.

Besides requiring low data rates, this selection mechanism is attractive for several other reasons. As the coordinates are determined only by the state (i.e. extended or contracted) of each cylinder, the mechanism does not have to return to a zero point before selecting the next frame; this speeds the operation of the mechanism. Prototype models tested had a maximum selection time of 0.2 seconds. The mechanical simplicity of the mechanism makes for accurate positioning; there are no adjustments to go wrong. In addition, the cylinders themselves can be cheaply mass-produced out of plastics, cutting down terminal hardware costs.

#### A.2.2 Random Access Audio System

The random access audio system also uses pneumatic cylinders. A disk of Mylar-based magnetic recording material (typically twelve inches in diameter) is mounted upon a high moment of inertia, rim-driven turntable which rotates at an angular velocity of 1/8 revolution per second. Messages are recorded on 64 circular tracks, each track having been divided into 32 equal segments of quarter-second duration. Through the use of half-track heads, which effectively double the number of available tracks to 128, up to 17.1 minutes of audio message can be recorded per disc.

To find any particular message unit first requires selection of the appropriate track. This is done in much the same manner as the image selector; a magnetic record/playback head is radially positioned by a

• • • • set of six series-mounted pneumatic cylinders with weights of 32, 16, 8, 4, 2, 1, ( $2^5, 2^4, 2^3, 2^2, 2^1, 2^0$ ). As in the image selector, any particular track can be selected for the magnetic head by extending or contracting the weighted cylinders, the correct track being identified by a six bit address.

Were radial positioning only to be used, the worst case access time would correspond to one full rotation of the turntable, or eight seconds. To reduce this to an acceptable time, angular positioning is also needed. This can be accomplished by changing the angular position of the low moment of inertia magnetic disk with respect to the high moment of inertia turntable through linear translation of a helically grooved turntable center shaft.

A vertical groove in the center shaft is fitted by a keyed center hole in the turntable, forcing the shaft to rotate along with the turntable. The shaft, however, is free to move up and down with respect to the turntable. To allow displacement of the magnetic disc, a helical groove is also cut into the central shaft to which the keyed center hole of the disc is fitted. As the center shaft moves up and down, the helical groove forces the magnetic disc to rotate with respect to the turntable.

To determine the angular positioning needed, the present position of the turntable and the present position of the disc with respect to the turntable is needed. To provide turntable position information, markers are placed equi-distant along the circumference of the turntable which correspond to message unit boundaries; a special marker is used to denote the  $0^\circ$  angular reference point of the turntable ( $\theta_t = 0^\circ$ ). A detector positioned along the fixed radial path of

the magnetic head is connected to a counter which is reset to zero whenever the  $0^\circ$  marker is sensed and increments by one when each of the other markers is sensed. Consequently, the position of the turntable is known to within one message unit.

The positioning of the disc with respect to the turntable is indicated by the state of the set of weighted pneumatic cylinders controlling the vertical position of the shaft. As there are 32 message units per disc track, the set contains 5 series-mounted cylinders weighted  $2^4, 2^3, 2^2, 2^1, 2^0$ ; the length of the shortest is  $\Delta Z = 360^\circ \cdot \gamma / 32$  where  $\gamma$  is the pitch of the helical groove in the shaft (i.e., one message unit occupies an arc of  $\frac{360^\circ}{32}$ . Moving the center shaft a distance  $\Delta Z$  causes the disc to displace with respect to the turntable  $\frac{360^\circ}{32}$  or one message unit).

Knowing both these positions, digital logic is used to determine the disc displacement needed, correct for spinning of the turntable, and cause appropriate displacement of the disc by setting the states of the center shaft's positioning cylinders. Using both radial and angular positioning, the worst case access time is 0.4 seconds. By dividing the the disc into 64 tracks and using a half track magnetic head, at one resolution per eight seconds turntable angular velocity, 17 minutes of audio may be recorded upon one disc.

---

Reference: (1) D. Bitzer, K. Johnson, and D. Skaperdas; "A Digitally Addressable Random Access Image Selector and Random Access Audio System," August 1970, Computer-based Education Research Laboratory, University of Illinois, Urbana, Illinois.

REFERENCES

1. J. P. Singh and R. P. Morgan, Educational Electronic Information Dissemination and Broadcast Services: History, Current Infrastructure and Public Broadcasting Requirements, Program on Application of Communications Satellites to Educational Development, Internal Memorandum No. 71/3, Washington University, August 1971, pp. 6-13.
2. H. Busignies, "Communications Channels," Scientific American, September 1972, pp. 99-113.
3. Federal Communications Commission, Rules and Regulations Volume III, September 1972, Section 73.315b.
4. Radio Corporation of America, Broadcast RADIO/TV Equipment Price List, TV-700202, January 1970.
5. Personal Interview with Mr. A. McMasters, Chief Engineer for television station KETC, St. Louis, Mo., October 18, 1973.
6. Federal Communications Commission, *Ibid.*, Section 73.211.
7. Federal Communications Commission, *Ibid.*, Sections 73.313c and 73.333, Figure 1.
8. Personal Interview with Mike McGowen, Chief Engineer, Station KWMU-FM, St. Louis, Mo., October 22, 1974.
9. Radio Corporation of America, Broadcast RADIO/TV Equipment Price List, TV-700202, January 1970.
10. Federal Communications Commission, *Ibid.*, Section 73.11.
11. Federal Communications Commission, *Ibid.*, Section 73.182f.
12. Federal Communications Commission, *Ibid.*, Sections 73.182r and 73.184, Graph 13 (Freq. = 1.1 MHz, e = 15).
13. From class notes, EE 593, Instructor J. Singh, Washington University, March 15, 1973.
14. Federal Communications Commission, Educational Television, Inf. Bulletin No. 16-B, 9/72. (ERIC ED 069129)
15. J. Armsey and N. Dahl, An Inquiry Into the Use of Instructional Technology, Ford Foundation, 1973, pg. 55.
16. D. Jamison, M. Jamison, and S. Hewlett, "Satellite Radio: Better Than ETV," Astronautics and Aeronautics, October 1969, pp. 92-96.

17. Federal Communications Commission, Rules and Regulations Volume III, September 1972, Section 73.603, and telephone conversation with St. Louis Office of the Federal Communications Commission, Oct. 15, 1974.
18. Federal Communications Commission, Ibid., Section 73.610.
19. Federal Communications Commission, Ibid., Section 73.681.
20. Federal Communications Commission, Ibid., Section 73.614.
21. Federal Communications Commission, Ibid., Section 73.609.
22. Federal Communications Commission, Ibid., Section 73.685.
23. Federal Communications Commission, Ibid., Section 73.684 and 73.699, Figures 9 and 10.
24. Mathematica, Inc., Evaluation of the Market for Instructional Television and the Effects of Changes In the Communications Industry: Volume II, Delivery Systems, Princeton, N.J., December 1973, pg. 7-148.
25. Mathematica, Inc., Ibid., pg. 7-146.
26. Mathematica, Inc., Ibid., pg. 7-147.
27. Singh and Morgan, Ibid., pp. 21-35.
28. K. Stetten and J. Volk, Interactive Television: Volume I, Introduction and Interim Summary, M72-200, The Mitre Corporation, May 1973.
29. K. Stetten, Toward A Market Success for CAI, An Overview of the TICCIT Program, M72-73, The Mitre Corporation, June 1972.
30. J. Ball and T. Eller, Interactive Television: Volume II, Technical and Economic Considerations, M72-200, The Mitre Corporation, Feb. 1974.
31. T. Eller and J. Volk, An Experimental Demonstration of Home Delivery of Educational Services by Interactive Television, M74-39, The Mitre Corporation, May 20, 1974.
32. Analysis of Some Queueing Models in Real Time Systems, IBM Publication #GF20-0007-1, Second Edition, pgs. 45-46.
33. Newsweek, 7-8-74, pg. 55.
34. E. Dickson and R. Bowers, The Video Telephone, A New Era In Telecommunications: A Preliminary Technology Assessment, NSF-RA-S-73-004, Cornell University, June 1973, pp. 9-44.
35. I. Corros, "Picturephone," Bell Laboratories Record, May/June 1969, pp. 136-141.

36. C. G. Davis, "Getting the Picture," Bell Telephone Record, May/June 1969, pp. 142-147.
37. H. Falk, "Picturephone and Beyond," IEEE Spectrum, November 1973, pp. 45-49.
38. Dickson and Bowers, Ibid., pp. 187-194.
39. D. Alpert and D. Bitzer, "Advances in Computer-Based Education: A Progress Report on the PLATO Program," CERL Report X-10, July 1969, Computer-Based Education Research Laboratory, University of Illinois, Urbana, Illinois, Table II.
40. R. A. Avner and P. Tenczar, "The TUTOR Manual," CERL Report X-4, January 1969, Computer-Based Education Research Laboratory, University of Illinois, Urbana, Illinois.
41. D. Alpert and D. Skaperdas, "The Design of an Economically Viable Large-Scale Computer Based Education System," CERL Report X-5, July 1973, Computer-Based Education Research Laboratory, University of Illinois, Urbana, Illinois, pp. 7-16.
42. D. Bitzer and R. Johnson, "PLATO: A Computer-Based System Used in the Engineering of Education," Proceedings of the IEEE, Vol. 59, No. 6, June 1971, pp. 960-968.
43. D. Bitzer, R. Johnson, and D. Skaperdas, "A Digitally Addressable Random Access Image Selector and Random Access Audio System," CERL Report X-13, August 1970, Computer-Based Education Research Laboratory, University of Illinois, Urbana, Illinois, pg. 8-15.
44. Alpert and Bitzer, Ibid., pp. 16-24.
45. J. Stifle, D. Bitzer, and M. Johnson, "Digital Data Transmission Via CATV," CERL Report X-26, May 1972, Computer-Based Education Research Laboratory, University of Illinois, Urbana, Illinois, pg. 3.
46. Malarkey, Taylor and Associates, "Pilot Projects for the Broadband Communications Distribution System," November 1971, Malarkey Taylor, and Associates, Washington, pg. 87.
47. J. Stifle, "The PLATO IV Architecture," CERL Report X-20, April 1971, Computer-Based Education Research Laboratory, University of Illinois, Urbana, Illinois, pg. 1-5.
48. C. Bailey Neal, "A Consumer-Economics View of Proposed CATV Channel Assignment Plans," IEEE Transactions on Broadcast and Television Receivers, Vol. BTR-19, No. 1, February 1973.
49. R. Simonsen and K. Renshaw, "CAI-Boon or Boondoggle," Datamation, March 1974, Vol. 20., No. 3, pp. 90-102.

50. D. Castigan, Fax, The Principles and Practices of Facsimile Communication, 1971, Chilton Book Company, Philadelphia.
51. H. E. Westaway, "A Fresh Look at Facsimile Transmission," P.O.E.E.J., pp. 18-24, 1973.
52. Denver Research Institute, "Technological Innovations in Video and Their Potential Market; Institutional and Consumer Impacts." NTIS, (COM-73-11455).
53. J. Volk, "Two-way CATV's Future Hinges on Inexpensive Frame Grabbers," Electronics, pp. 77-81, July 5, 1974.
54. R.C.A. Data Sheet #C22041, "Storage-Display Tube, Developmental Type," November, 1971.
55. W.D. Petty and H. G. Slottow, "Multiple States and Variable Intensity in the Plasma Display Panel," IEEE Transactions on Electron Devices, Vol. ED-18, No. 9, Sept. 1971, pp. 654-658.
56. D. R. Knudson and R. S. Marcus, "The Design of a Microimage Storage and Transmission Capability into an Integrated Information Transfer System," The Journal of Micrographics, Vol. 6, No. 1, September 1972, pp. 15-20.
57. H. J. Hoehn and R. A. Martel, "A 60 line per inch Plasma Display Panel," IEEE Transactions on Electron Devices, Vol. ED-18, No. 9, September 1971, pp. 659-663.
58. C. Overhage and R. Harmon, ed., Intrex, Report of a Planning Conference on Information Transfer Experiments, M.I.T. Press, 1965.
59. H. W. Ballou, editor, Guide to Microreproduction Equipment, National Microfilm Association, 1971.
60. Personal conversation with Burton Granat, President of Microfilm Techniques, Inc., St. Louis, Missouri, June 3, 1974.
61. Massachusetts Institute of Technology, Project Intrex, Semi-annual Activity Report, 15 September 1972, Intrex PR-14, Cambridge, Massachusetts.
62. "First Commercial CCD Unveiled, A 1 x 500 Element Image Sensor," IEEE Spectrum, June 1973, pg. 65.
63. "CCD101, 500-Element Charge Coupled Linear Image Sensor," Fairchild Semiconductor, May, 1973.
64. "Product Summary: Solid State Image Sensors and Systems," Reticon Corporation, 450 E. Middlefield Road, Mountain View, California 94043, Copyright 1974.

65. H. H. Poole, Fundamentals of Display Systems, Spartan Books, Washington, 1966, pg. 353.
66. J. Rothman, "The Times Information Bank," Urban Telecommunications Forum, Volume III, Number 3, March 1974, pp. 1-7.
67. Brooklyn Public Library, "New York Times Information Bank at Brooklyn Library," Urban Telecommunications Forum, May 1974, pg. 3.
68. Barnett, H. J. and A. T. Densau, "Future Development of Instructional Television," Memorandum 71/5, (43 pp), November, 1971 (with assistance from J. R. DuMolin and J. P. Singh). (ERIC No. 057 574) [NASA-CR-124700]
69. Morgan, R. P., "Communications Technology in the Future of Higher Education in the United States," Symposium on Communications Media and the Future of Higher Education, Stuttgart, Germany, November 2-4, 1973.
70. Rothenberg, D., "Vocational/Technical Education: Status, Trends and Issues, Related to Electronic Delivery," Memorandum No. 73/1, January, 1973. (ERIC No. ED 071 438) [NASA-CR-130532].
71. Rothenberg, D., "Early Childhood Education: Status, Trends and Issues Related to Electronic Delivery," Memorandum No. 73/2, (111 pp), May, 1973. (ERIC No. ED 077 217) [NASA-CR-133028].
72. Walkmeyer, J., "Planning Alternative Organizational Frameworks For A Large Scale Educational Telecommunications System Served by Fixed/Broadcast Satellites," Memorandum No. 73/3, (112 pp), June, 1973. (ERIC No. ED 078 663) [NASA-CR-133646].
73. Rothenberg, D., "Education of the Handicapped: Status, Trends and Issues Related to Electronic Delivery," Memorandum 73/4, (92 pp), December 1973.
74. Morgan, R. P., J. P. Singh, D. Rothenberg, and B. E. Robinson, "Large-Scale Educational Telecommunications Systems for the U.S.: A Preliminary Analysis of Educational Needs and Technological Opportunities," (forthcoming).
75. Walkmeyer, J., "Market Scenarios and Alternative Administrative Frameworks for Educational Satellite Systems," (forthcoming).